

Hella-Spiegelprogramm

Hella Mirrors

Rétroviseurs Hella

Programa de retrovisores de Hella

Programma Specchi Hella

Spiegelprogramma van Hella



***Ideas today for
the cars of tomorrow***

**Hier erläutern wir Ihnen
die Hella-Piktogramme.**

**The Hella pictograms
explained.**

**Vous trouverez ici la signification
des pictogrammes Hella.**

**A continuación le presentamos
los pictogramas de Hella.**

**Qui trovate la legenda dei
simboli Hella.**

**Hier lichten wij de pictogrammen
van Hella toe.**

Hella KGaA Hueck & Co.
Kunden-Service-Center
Rixbecker Straße 75
59552 Lippstadt / Germany
Internet: www.hella.com

Deutschland:
Tel.: 01 80-5-25 00 01 (0,12 €/Min.)
Fax: 01 80-2-25 00 01 (0,06 €
je Verbindung)

International:
Tel.: +49 (0) 29 41/38-0
Fax: +49 (0) 29 41/38-79 64

Hella BV
Celsiusbaan 2, Postbus 1398
3430 BJ Nieuwegein
Tel.: 030 6095611
Telefax: 030 6051677
E-Mail: nl.info@hella.com
Internet: www.hella.nl

Hella Handel Austria GmbH
Zentrale Wien:
Deutschstraße 6
1239 Wien / Österreich
Tel.: +43 (0) 1/614 60-0
Fax: +43 (0) 1/614 60-41
verkauf.wien@hella.com
www.hella.at

Niederlassung Linz:
Nebingerstraße 3
4020 Linz / Österreich
Tel.: +43 (0) 732/66 38 52-0
Fax: +43 (0) 732/66 38 52-15
verkauf.linz@hella.com

Hella N.V./S.A.
Industrieweg 1
2630 Aartselaar
T 03-887 97 21
F 03-887 56 18
E.be.info@hella.com
I www.hella.be

Hella spa
Via Piemonte, 17 – Fraz. Sesto
Ulteriano
San Giuliano Milanese (MI)
Tel.: 02 98835.1
Tel.: 199 792 792
Fax: 02 98835.235-236
E-mail: infoitalia@hella.com
Internet: www.hella.it

Hella spa – Deposito di Roma
Via Melibeo, 72-78
00155 ROMA
Tel.: 06 227002.1
Fax: 06 227002.262
E-mail: infoitalia@hella.com

Importør:

Hellanor:

Industriveien 26, 1481 Hagan
Postboks 44, 1483 Skytta
Tlf. 67 06 60 00
Fax 67 06 60 10
e-mail: hellanor@hellanor.no
Internet: www.hellanor.no

Maahantuonti, tukkumyynti:

ÖRUM









Läntinen teollisuuskatu 2, PL 14,
02921 ESPOO
Puh. myynti 010 569 4455,
telefax 010 569 4550
Internet: www.orum.fi

	Spiegelkopf mit Glas Mirror head with glass Tête de rétroviseur avec glace Cuerpo con espejo Coppa specchio con vetro Spiegelkop met glas		Ersatzglas Replacement glass Miroir de remplacement Espejo de repuesto Vetro specchio di ricambio Vervangingsglas		Montage auf Spiegelstange Mounted on mirror arm Pose sur tige rétroviseur Montaje sobre brazo de Montaggio su braccio Montage op spiegelstang		Rundstecker, 6-polig 6-pole round plug Connecteur rond, 6 pôles Enchufe redondo de 6 polos Spina tonda a 6 poli 6-polige rondstekker
	Spiegelkopf ohne Glas Mirror head without glass Tête de rétroviseur sans glace Cuerpo sin espejo Coppa specchio senza vetro Spiegelkop zonder glas		Anbauseite, links und rechts Mounting side, left and right Côté montage, gauche et droite lado de montaje, izq. y der. Lato montaggio, sinistro e destro Montagezijde, links en rechts		Nennspannung/ beheizbar Volt/ heated Volt/ chauffant Volt/ térmico Volt/ termico Volt/ verwarmbaar		Winkelstecker, 2-polig 2-pole angular plug Connecteur angulaire, 2 pôles Enchufe acodado de 2 polos Spina angolare bipolare 2-polige haakse stekker
	Busspiegel mit Gelenkarm Bus mirror with joint arm Rétroviseur de car avec bras articulé Retrovisor para autocar con brazo articulable Specchio per autobus con braccio snodabile Busspiegel met scharnierarm		Anbauseite, links Mounting side, left Côté montage, gauche lado de montaje, izq. Lato montaggio, sinistro Montagezijde, links		Nennspannung/ beheizbar Volt/ heated Volt/ chauffant Volt/ térmico Volt/ termico Volt/ verwarmbaar		Mit Einfachschalter With single switch Avec interrupteur simple Con interruptor simple Con connettore singolo Met enkele schakelaar
	Busspiegel, hängend Bus mirror, pendant mounting Rétroviseur de car, montage suspendu Retrovisor para autocar, montaje en posición invertida Specchio per autobus, montaggio appeso Busspiegel, hangend		Anbauseite, rechts Mounting side, right Côté montage, droite lado de montaje, der. Lato montaggio, destro Montagezijde, rechts		Elektrisch verstellbar Electrically adjustable Réglable électriquement Ajuste eléctrico Regolazione elettrica Elektrisch verstelbaar		Mit Doppelschalter With double switch Avec interrupteur double Con interruptor doble Con connettore doppio Met dubbele schakelaar
	Busspiegel, stehend Bus mirror, upright mounting Rétroviseur de car, montage posé Retrovisor para autocar, montaje en posición de pie Specchio per autobus, montaggio ritto Busspiegel, staand		Kunststoff, schwarz Plastic, black Matière plastique, noir Plástico, negro Plastica, nero Kunststof, zwart		Manuell verstellbar Manually adjustable Réglable manuellement Ajuste manual Regolazione manuale Manueel verstelbaar		Grundplatte Base plate Plaque de base Placa base Base Grondplaat
	Einstiegs-/ Bugbeobachtungsspiegel Front end observation/door observation mirror Miroir d'accès et d'observation à l'avant retrovisor panorámico y de observación delantera Specchio di salita e controllo anteriore Instap- en frontobservatiespiegel		Kunststoff, grau Plastic, grey Matière plastique, gris Plástico, gris Plastica, grigia Kunststof, grijs		Typgeprüft Type approved Avec homologation Con homologación Con omologazione Met E-keur		Haltergruppe Holder set Groupe support Grupo de soportes Gruppo per supporto Houdergroep
	Bugbeobachtungsspiegel Door observation mirror Miroir d'observation à l'avant Retrovisor observación delantera Specchio di controllo anteriore Frontobservatiespiegel		Stahl Steel Acier Acero Acciaio Staal		Spiegelstange Mirror arm Tige de rétroviseur Brazo Braccio Spiegelstang		Befestigungsmaterial Fastening material Matériel de fixation Con medios de fijación Con elemento di fissaggio Bevestigingsmateriaal
	Weitwinkelspiegel Wide-angle mirror Rétroviseur angle large Retrovisor panorámico Specchietti a grandangolo Groothoekspegel		Breite/Höhe/Durchmesser Width/Height/Diameter Largeur/Hauteur/Diamètre Anchura/Altura/Diámetro Larghezza/Altezza/Diametro Breedte/Hoogte/Diameter		Anschlussleitung Connecting cable Câble de connexion Cable de conexión Cablaggio Aansluitkabel		Abdeckung Cover Cache Cubierta Calotta di chiusura Afdekkap
	Rampenspiegel Ramp mirror Rétroviseur d'angle mort Retrovisor para ángulo muerto Specchio di rampa Dodehoekspegel		Spiegelglas mit Wölbungsradius Mirror glass with curved radius Surface du miroir avec rayon convexe Espejo con radio de curvatura Vetro-specchio con raggio di bombatura Spiegelglas met welvingsradius		Rundstecker, 2-polig 2-pole round plug Connecteur rond, 2 pôles Enchufe redondo de 2 polos Spina tonda bipolare 2-polige rondstekker		Motor Motor Moteur Motor Motorino Motor













<p>Verwendungsübersicht - Nkw, Transporter und Busse Application chart - Trucks, transporters and buses Liste des affectations - V.U.L., P.L., et bus Lista de aplicaciones - Vehículos industriales, camionetas y autobuses Panoramica applicazioni - Autocarri, furgoni e autobus Toepassingsoverzicht - Bestelauto's, vrachtwagens en bussen</p>	<p>2 - 78</p>
<p>Außenspiegel für Land- und Baumaschinen External mirrors for agricultural and construction machinery Rétroiseurs extérieurs pour machines agricoles et engins de chantiers Retrovisores exteriores para máquinas agrícolas y maquinarias para obras Specchi per macchine agricole- e movimento terra Spiegels voor landbouwmachines</p>	<p>79 - 81</p>
<p>Universalspiegel Universal mirrors Rétroiseurs extérieurs universels Retrovisores exteriores universales Specchi universali Universele spiegels</p>	<p>82 - 87</p>
<p>Ersatzteile und Zubehör für Busspiegel Spare parts and accessories for bus mirrors Pièces de rechange et accessoires pour rétroiseurs de cars Piezas de recambio y accesorios para autocares Ricambi e accessori per autobus Onderdelen en toebehoren voor busspiegels</p>	<p>88 - 97</p>
<p>Zubehör Accessories Accessoires Accesorios Accessori Toebehoren</p>	<p>98 - 100</p>
<p>Hersteller Nr. - Hella Nr. Manufacturer's No. - Hella-No. Références constructeurs - Références Hella Ref. del fabricante - N° de pedido Hella Comparazione no. originali - Codice Hella Vergelijgingslijst origineel nr. - Hella nr.</p>	<p>101 - 103</p>
<p>Prüfnummernübersicht Approval numbers Numéros d'homologation Números de homologación Nùmeros omologati Goedkeuringsnummers</p>	<p>104</p>

Auwärter E.	3 - 4	MAN	31 - 43
Avia	4	MAN/VW	43
Berkhof	5 - 6	Mannesmann-Demag	44
Bova	7 - 8	Mercedes-Benz	45 - 54
Büssing	8	Mitsubishi	54 - 55
Caetano	9	Neoplan	56 - 63
Carthago	9	Nissan	63
Concorde	10	O&K	64
DAF	10 - 11	ÖAF	64
Drögmöller	12 - 13	RMB	65
EOS	13	Saurer	65
EvoBus	14 - 16	Scania	66
Faun	16 - 17	Sisu	67
Fiat	17	Steyr	67 - 68
Hanomag-Henschel	18	Temsa	68
Hino	18 - 19	Van Hool	69 - 71
Hymer	19 - 21	VARIOmobil	71
Irisbus	21	Vetter	72
Irizar	22	Volkswagen	72 - 75
Iveco	22 - 24	Volvo	75 - 78
Jonckheere	24 - 27		
Kässbohrer	27		
Krupp	28		
LAG	29		
LIAZ	29		
Liebherr	30		
LMC	30		

   					
Auwärter E.					
<p>Eurostar SHD</p> 	<p>8SB 501 246-892</p>	              		<p>2100, 450, 240</p>	
Avia					
<p>A 21, A 31 (Light-weight class)</p> 	<p>8SB 501 156-021</p> <p>9EY 120 010-001</p> <p>8SB 501 156-031</p> <p>9MX 561 891-001</p> <p>8KA 500 218-002</p>	                               	<p>186x375</p> <p>186x375</p> <p>1150</p>	<p>2200</p> <p>2200</p>	<p>15-20</p> <p>15-20</p>

Berkhof					
Buses 	8SB 501 246-834			2100, 450	
	8SB 501 246-803			2100, 450	
	8SB 501 247-803			2100	

Berkhof							
Buses		8SB 501 247-842	     		2100		
Bova							
Futura		82->86	8SB 003 978-041 9MX 127 585-002 8HS 562 691-002 8KA 003 806-001	          	182x367	2200	18-22
					2000		18-22
		86->92	8SB 501 081-041 9MX 561 449-001 8HS 562 691-002 8KA 003 806-001	          	200x422	2200	18
					2000		18

Bova						
Futura 	8SB 501 246-834			2100, 450		
	8SB 501 246-803			2100, 450		
Büssing						
Trucks to 7.5 t and over Trucks to 7.5 t and over, buses, e.g. VÖV buses 	8SB 002 993-001 9EY 117 125-001		180x260	1400	15	



Büssing

Trucks to 7.5 t and over

Trucks to 7.5 t and over,
buses, e.g. VÖV buses



8SB 002 405-001

9EY 111 231-001



155x270

1400

10-12

8SB 002 405-011

9EY 111 231-001



155x270

1400

15-18



8SB 002 991-182



9EY 117 126-014









































220x310

18



Caetano								
Buses								
	8SB 501 081-031					200x422	2200	18
	9EY 561 445-001							
Carthago								
Mobil homes								
	8SB 501 247-752						2100, 450	
	8SB 501 247-742						2100, 450	

Concorde							
Travel mobil 	8SB 501 247-772			2100, 450			
	8SB 501 247-782			2100, 450			
	8SB 501 247-895			2100			
	8SB 501 247-905			2100			
DAF							
CF 65, CF 75, CF 85 01/01-> 	8SB 354 507-001 9HB 863 833-001 9MX 863 845-001			205x384	2000	22-28	

				   		
DAF						
CF 65, CF 75, CF 85 01/01-> 	8SB 354 508-001 9HB 863 833-001 9MX 863 846-001	       	170x219	450	22-28	
XF 95 09/02-> 	8SB 354 507-001 9HB 863 833-001 9MX 863 845-001	       	205x384	2000	22-28	
	8SB 354 508-001 9HB 863 833-001 9MX 863 846-001	       	170x219	450	22-28	



Drögmöller

E 280 - E 440

(Travel coaches)

- E 280, E 290
- E 320 (Europullmann)
- E 330 H (Eurocomet)
- E 330 K (Minicomet)
- E 420
- E 430 U (Supercomet)
- E 440 (Meteor)



8SB 501 081-031



200x422

2200

18

9EY 561 445-001



8SB 501 081-041



200x422

2200

18

9MX 561 449-001



8HS 562 691-002



18-22

8KA 003 806-001



2000

E 320 - E 430

- E 320, E 330, K
- E 330-11,3, E 330 H
- E 330 H-11,3
- E 430



8SB 501 246-892

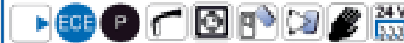













2100, 450,
240

Drögmöller					
Buses	8SB 501 602-822		2100		
EOS					
Buses	8SB 501 602-812		1800, 240		
	8SB 501 602-822		2100, 450, 240		
	8SB 501 246-822		2100		

EvoBus							
<p>Setra Kombi</p> 	8SB 501 247-803			2100			
<p>Buses</p> 	8SB 501 311-812			2100, 240			
	<p>8SB 501 325-012</p> <p>9HD 563 475-041</p> <p>9MX 563 468-002</p> <p>8HG 503 009-012</p> <p>8HG 503 009-022</p> <p>8HG 503 009-042</p> <p>8HG 503 009-052</p> <p>8HG 503 009-082</p> <p>8HG 503 019-012</p> <p>8HG 503 019-022</p>		<p>206x383</p> <p>128x450</p> <p>128x450</p> <p>128x450</p> <p>128x450</p> <p>128x450</p> <p>688x345</p> <p>688x345</p>	2100		22	













EvoBus											
Buses		8SB 501 325-002						206x383	2100	22	
		9HD 563 475-041									
		9MX 563 468-002									
		8HG 503 009-012							128x450		
		8HG 503 009-022							128x450		
		8HG 503 009-042							128x450		
		8HG 503 009-052							128x450		
		8HG 503 009-082							128x450		
		8HG 503 019-012							688x345		
		8HG 503 019-022							688x345		
Combibus		8SB 501 401-802							210x479	1800	
		8SB 501 401-822							210x479	1800	
		8SB 501 403-802									
		8SB 501 403-822									

EvoBus							
Citaro (O 530) 01/98-> 	8SB 501 401-802		210x479	1800			
	8SB 501 401-822		210x479	1800			
01/98-> 	8SB 501 402-802						
	8SB 501 402-822						
Faun							
Community service vehicles Community service vehicles, skip lorries, e.g. D 35 Heavy lorries for trailers Goliath, Gigant, Herkules, Koloss Fire-fighting crane RTT 50-4 	8SB 003 290-001		187x382	2100	14-18		
	9EY 120 010-001						
	8SB 003 290-011		187x382	2100	16-18		
	9MX 560 096-002						
	8KA 560 271-002		2000				

Faun						
Community service vehicles Community service vehicles, skip lorries, e.g. D 35 Heavy lorries for trailers Goliath, Gigant, Herkules, Koloss Fire-fighting crane RTT 50-4	8SB 002 994-001 9EY 117 127-001		160x265 1400 10			
		8SB 003 978-001 9EY 125 314-001		182x367 2100 18-22 182x367 2200 18-22 9MX 127 585-002 8HS 562 691-002 8KA 003 806-001 2000		
Fiat						
See Iveco						

Hanomag-Henschel								
<p>Small delivery vans and other trucks</p> 	<p>8SB 002 997-001 9EY 117 129-001</p>		131x186	1400	10			
<p>Construction machines</p> 	<p>8SB 002 993-001 9EY 117 125-001</p>		180x260	1400	15			
Hino								
<p>Trucks FD, FF, FG</p> 	<p>8SB 003 978-001 9EY 125 314-001</p>		182x367	2100	18-22			



Hino					
Trucks FD, FF, FG 	8SB 501 147-021		211x161	450	16-22
	9EY 561 814-001		1150		
	8KA 500 218-002		211x161	450	16-22
	8SB 501 147-031		1150		
	9MX 561 890-001				
	8KA 500 218-002				
Hymer					
Mobil homes 	8SB 501 156-021		186x375	2200	15-20
	9EY 120 010-001		186x375	2200	15-20
	8SB 501 156-031		1150		
	9MX 561 891-001				
		8KA 500 218-002			
	8SB 501 358-082		195x336	1800	22
	9MX 563 716-022				

Hymer							
Mobil homes 	8SB 501 147-021		211x161	450	16-22		
	9EY 561 814-001						
	8KA 500 218-002		1150				
	8SB 501 147-031		211x161	450	16-22		
	9MX 561 890-001						
	8KA 500 218-002		1150				
	8SB 501 247-752			2100, 450			
	8SB 501 247-742			2100, 450			
	8SB 501 247-792			2100, 450			

		   	
Hymer			
Mobil homes	8SB 501 247-895	      	2100
			
	8SB 501 247-905	      	2100
			
Irisbus			
Axer	8SB 501 403-802	           	
			

Irizar					
Century 	8SB 501 602-812		1800, 240		
	8SB 501 602-822		2100, 450, 240		
	8SB 501 246-803		2100, 450		
Iveco					
Trucks 	8SB 002 993-001		180x260	1400	15
	9EY 117 125-001				

Iveco							
EuroClass travel coach 380 HD, ND	8SB 501 247-803		2100				
110-13 A - 130-16 AH (MK-series)	8SB 003 978-001 9EY 125 314-001 8SB 003 978-041 9MX 127 585-002 8HS 562 691-002 8KA 003 806-001		182x367 182x367 2000	2100 2200 18-22	18-22 18-22 18-22		

Iveco							
<p>120-13 ANW - 120-13 ANW - 340-34 AH (P/PA-series construction vehicles)</p> <p>160-17 - 340-34 AH Tipper</p> <p>120-13 ANW - 330-36 HW Four-wheel-drive tipper</p> 	8SB 003 290-001		187x382	2100	14-18		
	9EY 120 010-001						
	8SB 003 290-011		187x382	2100	16-18		
	9MX 560 096-002						
	8KA 560 271-002		2000				
Jonckheere							
<p>Travel coaches Jubilee</p> <p>Travel coaches Jubilee, Deauville</p> <p>Overland bus Neuilly</p> <p>Route bus City 041 etc. travel coaches and route buses</p> 	8SB 003 978-041		182x367	2200	18-22		
	9MX 127 585-002						
	8HS 562 691-002				18-22		
	8KA 003 806-001		2000				



Jonckheere

Travel coaches Jubilee

Travel coaches Jubilee,
Deauville

Overland bus Neuilly

Route bus City 041 etc.
travel coaches and
route buses



8SB 501 081-031



200x422

2200

18

9EY 561 445-001



8SB 501 081-041



200x422

2200

18

9MX 561 449-001



8HS 562 691-002



18-22

8KA 003 806-001



2000

Jonckheere						
<p>Buses</p>	<p>8SB 501 325-032</p> <p>9HD 563 475-041</p> <p>8HG 503 009-012</p> <p>8HG 503 009-022</p> <p>8HG 503 009-042</p> <p>8HG 503 009-052</p> <p>8HG 503 009-082</p> <p>8HG 503 019-012</p> <p>8HG 503 019-022</p>	<p></p> <p></p> <p></p> <p></p> <p></p> <p></p> <p></p> <p></p> <p></p> <p></p>	<p>206x383</p> <p>128x450</p> <p>128x450</p> <p>128x450</p> <p>128x450</p> <p>128x450</p> <p>128x450</p> <p>688x345</p> <p>688x345</p>	<p>2100</p> <p>2100</p>	<p>22</p> <p>22</p>	
	<p>8SB 501 325-012</p> <p>9HD 563 475-041</p> <p>9MX 563 468-002</p> <p>8HG 503 009-012</p> <p>8HG 503 009-022</p> <p>8HG 503 009-042</p> <p>8HG 503 009-052</p> <p>8HG 503 009-082</p> <p>8HG 503 019-012</p> <p>8HG 503 019-022</p>	<p></p> <p></p> <p></p> <p></p> <p></p> <p></p> <p></p> <p></p> <p></p> <p></p> <p></p>	<p>206x383</p> <p>128x450</p> <p>128x450</p> <p>128x450</p> <p>128x450</p> <p>128x450</p> <p>128x450</p> <p>688x345</p> <p>688x345</p>	<p>2100</p>	<p>22</p>	
		<p>8SB 501 325-002</p> <p>9HD 563 475-041</p> <p>9MX 563 468-002</p> <p>8HG 503 009-012</p> <p>8HG 503 009-022</p> <p>8HG 503 009-042</p> <p>8HG 503 009-052</p> <p>8HG 503 009-082</p> <p>8HG 503 019-012</p> <p>8HG 503 019-022</p>	<p></p> <p></p> <p></p> <p></p> <p></p> <p></p> <p></p> <p></p> <p></p> <p></p>	<p>206x383</p> <p>128x450</p> <p>128x450</p> <p>128x450</p> <p>128x450</p> <p>128x450</p> <p>128x450</p> <p>688x345</p> <p>688x345</p>	<p>2100</p>	<p>22</p>

Jonckheere						
Buses 	8SB 501 602-812		1800, 240			
	8SB 501 602-822		2100, 450, 240			
Kässbohrer						
Setra S 210 - S 250 S 210 H, HI Travel coach S 213 UL S 215 HDH/NR, S 216 HDS Super double-decker S 219 SL urban route articulated bus S 228 DT double-decker travel coach S 250 Special Regional, overland route bus 	8SB 003 978-001		182x367	2100	18-22	
	9EY 125 314-001					
	8SB 003 978-041		182x367	2200	18-22	
	9MX 127 585-002					
	8HS 562 691-002					18-22
8KA 003 806-001		2000				



Kässbohrer

Setra S 210 - S 250

S 210 H, HI
 Travel coach
 S 213 UL
 S 215 HDH/NR,
 S 216 HDS
 Super double-decker
 S 219 SL urban route
 articulated bus
 S 228 DT double-decker
 travel coach
 S 250 Special
 Regional, overland
 route bus



8SB 501 081-031



200x422

2200

18

9EY 561 445-001



8SB 501 081-041



200x422

2200

18

9MX 561 449-001



8HS 562 691-002



18-22

8KA 003 806-001



2000

Krupp

Trucks



8SB 003 290-001



187x382

2100

14-18

9EY 120 010-001



8SB 003 290-011



187x382

2100

16-18

9MX 560 096-002



8KA 560 271-002



2000

LAG						
Buses 	8SB 003 978-041 9MX 127 585-002 8HS 562 691-002 8KA 003 806-001	 	182x367	2200	18-22	
			2000		18-22	
	LIAZ					
	18.33 TBV, 19.33 TBV (heavy-weight class) 	8SB 501 156-021 9EY 120 010-001	 	186x375	2200	15-20
	8SB 501 137-031 8SB 501 137-001	 	247x157	450		



Liebherr

Vehicle cranes, e.g.

102 K slewing crane
 LTM 1040 - 3 telecrane
 LTM 1025 - LTM 1800
 Automobile crane
 LTM 1120 (Progress 2000)



8SB 003 290-001



187x382

2100

14-18

9EY 120 010-001



8SB 003 290-011



187x382

2100

16-18

9MX 560 096-002



8KA 560 271-002



2000

LMC

Travel mobil



8SB 501 247-895



2100



8SB 501 247-905



2100

MAN							
Buses 	8SB 560 991-012			186x320	2200	16-18	
	9EY 561 042-002						
	8KA 560 271-002			2000			
	8SB 560 991-041			186x320	2200	16-18	
	9MX 561 044-002						
	8KA 560 271-002			2000			
	8SB 002 990-001				1400	18	
	9EY 117 124-001						
	8SB 003 978-001			182x367	2100	18-22	
	9EY 125 314-001						
	8SB 003 978-041			182x367	2200	18-22	
	9MX 127 585-002						
	8HS 562 691-002						18-22
	8KA 003 806-001			2000			

MAN							
Buses		8SB 501 081-031 9EY 561 445-001		200x422	2200	18	
		8SB 501 602-812		1800, 240			
		8SB 501 247-822		2100, 450			

MAN			
Buses 	8SB 501 311-842		2100, 240
UEL 313/353 	8SB 501 247-812		2100



MAN

Route buses City

Solarisbuses



Route buses City
 NG 263, NG 313
 NL 263
 NM 223, NM 313
 NY 263





8SB 501 325-012		206x383	2100	22
9HD 563 475-041				
9MX 563 468-002				
8HG 503 009-012		128x450		
8HG 503 009-022		128x450		
8HG 503 009-042		128x450		
8HG 503 009-052		128x450		
8HG 503 009-082		128x450		
8HG 503 019-012		688x345		
8HG 503 019-022		688x345		
8SB 501 325-032		206x383	2100	22
9HD 563 475-041				
8HG 503 009-012		128x450		
8HG 503 009-022		128x450		
8HG 503 009-042		128x450		
8HG 503 009-052		128x450		
8HG 503 009-082		128x450		
8HG 503 019-012		688x345		
8HG 503 019-022		688x345		



8SB 501 325-002		206x383	2100	22
9HD 563 475-041				
9MX 563 468-002				
8HG 503 009-012		128x450		
8HG 503 009-022		128x450		
8HG 503 009-042		128x450		
8HG 503 009-052		128x450		
8HG 503 009-082		128x450		
8HG 503 019-012		688x345		
8HG 503 019-022		688x345		

MAN					
ÜL 313/353 	8SB 501 246-812			2100	
Lions Star FRH 322, FRH 372, FRH 422 	8SB 501 247-803			2100	

MAN							
<p>Lions Star FRH 322, FRH 372, FRH 422</p>	<p>8SB 501 246-892</p>		<p>2100, 450, 240</p>				
<p>Trucks F-types</p>	<p>70-></p>	<p>8SB 002 990-001 9EY 117 124-001</p>		<p>220x420</p>	<p>1400</p>	<p>18</p>	
<p>Trucks to 7.5 t</p>		<p>8SB 002 993-001 9EY 117 125-001</p>		<p>180x260</p>	<p>1400</p>	<p>15</p>	

MAN					
Trucks 	8SB 002 991-001		210x300	1400	18
	9EY 117 126-001				
	8SB 501 081-031		200x422	2200	18
	9EY 561 445-001				



MAN

8.113 - 10.224
(L 2000-series)

10/93->



8SB 501 325-012



206x383

2100

22

9HD 563 475-041



9MX 563 468-002



128x450

8HG 503 009-012



8HG 503 009-022



128x450

8HG 503 009-042



128x450

8HG 503 009-052



128x450

8HG 503 009-082



128x450

8HG 503 019-012



688x345

8HG 503 019-022



688x345

8SB 501 325-032



206x383

2100

22

9HD 563 475-041



8HG 503 009-012



128x450

8HG 503 009-022



128x450

8HG 503 009-042



128x450

8HG 503 009-052



128x450

8HG 503 009-082



128x450

8HG 503 019-012



688x345

8HG 503 019-022



688x345



8SB 501 325-002



206x383

2100

22

9HD 563 475-041



9MX 563 468-002



128x450

8HG 503 009-012



8HG 503 009-022



128x450

8HG 503 009-042



128x450

8HG 503 009-052



128x450

8HG 503 009-082



128x450

8HG 503 019-012



688x345



8HG 503 019-022



688x345

MAN						
10.136 F, 10.150 F (G, G 90-series)	10/93->09/93 	8SB 560 991-012		186x320	2200	16-18
		9EY 561 042-002 8KA 560 271-002		2000		
		8SB 560 991-041 9MX 561 044-002 8KA 560 271-002		186x320	2200	16-18
		8SB 501 137-031 8SB 501 137-001		247x157	450	
11.136 - 38.320	10/75-> 	8SB 003 290-001		187x382	2100	14-18
		9EY 120 010-001 8SB 003 290-011		187x382	2100	16-18
		9MX 560 096-002 8KA 560 271-002		2000		

MAN								
<p>12.152 - 24.272 (M 90-series)</p> <p>08/88-></p> 	<p>8SB 501 156-021</p> <p>9EY 120 010-001</p> <p>8SB 501 156-031</p> <p>9MX 561 891-001</p> <p>8KA 500 218-002</p>	    	186x375	2200	15-20	186x375	2200	15-20
			1150					
	<p>8SB 501 147-021</p> <p>9EY 561 814-001</p> <p>8KA 500 218-002</p> <p>8SB 501 147-031</p> <p>9MX 561 890-001</p> <p>8KA 500 218-002</p>	     	211x161	450	16-22	211x161	450	16-22
			1150					
<p>19.242 - 48.502 (F 90-series)</p> <p>08/88->09/94</p> 	<p>8SB 501 156-021</p> <p>9EY 120 010-001</p> <p>8SB 501 156-031</p> <p>9MX 561 891-001</p> <p>8KA 500 218-002</p>	    	186x375	2200	15-20	186x375	2200	15-20
			1150					
	<p>8SB 501 147-021</p> <p>9EY 561 814-001</p> <p>8KA 500 218-002</p> <p>8SB 501 147-031</p> <p>9MX 561 890-001</p> <p>8KA 500 218-002</p>	     	211x161	450	16-22	211x161	450	16-22
			1150					

MAN							
<p>18.310 - 41.660 (TG-A) 18.310 - 41.660 (TG-A) 03/00-></p> 	<p>8SB 354 509-001 9MX 863 847-001</p>		185x324	450			
MAN/VW							
<p>6.90 F - 9.150 F (G, G 90-series) 10/79->09/93</p> 	<p>8SB 560 991-012 9EY 561 042-002 8KA 560 271-002 8SB 560 991-041 9MX 561 044-002 8KA 560 271-002</p>		186x320	2000	186x320	2200	16-18
	<p>8SB 501 137-031 8SB 501 137-001</p>		247x157	450			

Mannesmann-Demag							
Construction machines Construction machines, automobile cranes, e.g. AC 615, AC 1600, CT 40, TC 3600, TC 3800, TC/PC 4200 CC	8SB 003 290-001			187x382	2100	14-18	
	9EY 120 010-001						
Mercedes-Benz							
Older truck models	8SB 002 995-011			158x241	2200		
	8SB 002 995-001			158x241	2200		

Mercedes-Benz								
Atego I, II Atego I Atego II Axor	01/98->	8SB 507 046-001		170x380		28		
	01/98->	9HD 564 236-001						
	01/02->	9MX 564 235-011		2000				
		8SB 507 046-011		170x380		28		
		9HD 564 236-001						
		9MX 564 235-011			2000			
L 206 - L 307 L 206 - L 307 (T1-series)	->04/77	8SB 003 609-061		138x210	1400	10		
LP 608 - LP 1113 (LP-series)	01/79->	8SB 003 614-001		184x305	2200	18-22		
		9EY 122 979-001						
		8SB 003 614-081		184x305	2200	18-22		
		9MX 127 586-032						
		8HS 562 691-002				18-22		
		8KA 003 806-001		2000				
		8SB 003 614-011		184x305	2200	18-22		
		9MX 127 586-001						
		8HS 562 691-002				18-22		
		8KA 003 806-001		2000				

Mercedes-Benz							
LP 608 - LP 1113 (LP-series)		01/79->	8SB 003 978-001	182x367	2100	18-22	
			9EY 125 314-001				
			8SB 003 978-041		182x367	2200	18-22
			9MX 127 585-002				
			8HS 562 691-002				18-22
		8KA 003 806-001		2000			
Route buses and travel coaches Route buses and travel coaches, etc. O 303/10 RHS, O 303/14 RHD, O 402, O 404, O 405 N/G			8SB 002 995-001	158x241	2200		
			8SB 002 995-091		158x241	2200	12
			8SB 003 614-001	184x305	2200	18-22	
		9EY 122 979-001					
		8SB 003 614-081		184x305	2200	18-22	
		9MX 127 586-032					
		8HS 562 691-002				18-22	
		8KA 003 806-001		2000			
		8SB 003 614-011		184x305	2200	18-22	
		9MX 127 586-001					
	8HS 562 691-002				18-22		
		8KA 003 806-001		2000			



Mercedes-Benz

Sprinter

Sprinter
Platform truck
(2300 mm vehicle width)

02/95->



8SB 507 042-041



177x283 2000

9MX 564 232-001



8SB 507 043-041



177x283 2000

9MX 564 233-001



8SB 507 042-051



177x283 2000

9MX 564 232-011



8SB 507 043-051



177x283 2000

9MX 564 233-011



Unimog 403 - 421

->06/78



8SB 002 994-001



160x265 1400 10

9EY 117 127-001



Unimog 425, 435

07/78->



8SB 003 290-001





187x382 2100 14-18

9EY 120 010-001



Mercedes-Benz							
Unimog 	8SB 501 358-002				195x336	1800	22
	9MX 563 709-012						
	8SB 501 358-012				195x336	1800	22
	9MX 563 716-022						
	8SB 501 358-032				195x336	1800	22
	9MX 563 716-032						
	8SB 501 359-002				189x195	450	22
	9MX 563 710-012						
	8SB 501 359-012				189x195	450	22
	9MX 563 717-022						
	8SB 501 359-022				189x195	450	22
	9MX 563 717-032						
Vario 10/96-> 	8SB 501 358-002				195x336	1800	22
	9MX 563 709-012						
	8SB 501 358-012				195x336	1800	22
	9MX 563 716-022						
	8SB 501 358-082				195x336	1800	22
	9MX 563 716-022						
	8SB 501 358-032				195x336	1800	22
	9MX 563 716-032						
10/96-> 	8SB 501 359-002				189x195	450	22
	9MX 563 710-012						
	8SB 501 359-012				189x195	450	22
	9MX 563 717-022						
	8SB 501 359-022				189x195	450	22
	9MX 563 717-032						

Mercedes-Benz							
<p>230 G - 300 GD (W 460)</p> <p>05/79-></p> 	<p>8SB 003 609-061</p>		138x210	1400	10		
<p>507 D - 814 D (T2, LN1-series)</p> <p>01/86-></p> 	<p>8SB 003 614-001</p> <p>9EY 122 979-001</p> <p>8SB 003 614-081</p> <p>9MX 127 586-032</p> <p>8HS 562 691-002</p> <p>8KA 003 806-001</p> <p>8SB 003 614-011</p> <p>9MX 127 586-001</p> <p>8HS 562 691-002</p> <p>8KA 003 806-001</p>	 	184x305	2200	18-22		
			184x305	2200	18-22		
			2000				18-22
			184x305	2200	18-22		
							18-22
			2000				
<p>709 - 1524 (LK, LN2-series)</p> <p>03/84-></p> 	<p>8SB 003 614-001</p> <p>9EY 122 979-001</p> <p>8SB 003 614-081</p> <p>9MX 127 586-032</p> <p>8HS 562 691-002</p> <p>8KA 003 806-001</p> <p>8SB 003 614-011</p> <p>9MX 127 586-001</p> <p>8HS 562 691-002</p> <p>8KA 003 806-001</p>	 	184x305	2200	18-22		
			184x305	2200	18-22		
							18-22
			2000				
			184x305	2200	18-22		
							18-22
			2000				

Mercedes-Benz							
709 - 1524 (LK, LN2-series)	03/84-> 	8SB 003 978-001		182x367	2100	18-22	
		9EY 125 314-001					
		8SB 003 978-041		182x367	2200	18-22	
		9MX 127 585-002					
		8HS 562 691-002					18-22
		8KA 003 806-001		2000			
1013 - 2632 (New generation)	01/79-> 	8SB 003 978-001		182x367	2100	18-22	
		9EY 125 314-001					
		8SB 003 978-041		182x367	2200	18-22	
		9MX 127 585-002					
		8HS 562 691-002					18-22
		8KA 003 806-001		2000			
1422 - 2633	01/80-> 	8SB 501 081-031		200x422	2200	18	
		9EY 561 445-001					
		8SB 501 081-041		200x422	2200	18	
		9MX 561 449-001					
		8HS 562 691-002					
		8KA 003 806-001		2000			18-22
		8SB 501 081-082		200x422	1800	18-22	
		9MX 562 236-003					

Mercedes-Benz						
2527 - 5035 (SK-series)	01/91->	8SB 501 274-001 9EY 563 168-001 9MX 563 167-001 8SB 501 273-001 9EY 563 168-001 9MX 563 167-001		182x440 182x440	2000 2000	28 28
Mitsubishi						
Canter FE 306, FE 331 Canter FE 306, FE 331, FE 334, FE 444, FB 436		8SB 002 995-011		158x241	2200	
Canter 8.5t Canter 8.5t	94->	8SB 501 147-003		161x211	450	18-22

Mitsubishi					
Pajero 	8SB 003 609-061		138x210	1400	10
F 415, FH 100, FK 315 	8SB 560 991-012 9EY 561 042-002 8KA 560 271-002 8SB 560 991-041 9MX 561 044-002 8KA 560 271-002		186x320	2200	16-18
FK 455, FP 418, FU 418, FU 515, FV 438 	8SB 003 290-001 9EY 120 010-001		187x382	2100	14-18



Neoplan

Buses

Buses, e.g.
 Cityliner N 116
 Spaceliner N 117/3
 Skyliner N 122/3
 Jetliner N 208
 Airport service bus
 N 940
 Metroliner N 4008
 Low-platform busses
 N 4009, N 4021
 SG, Transliner K

74->



8SB 003 290-011



187x382

2100

16-18

9MX 560 096-002



8KA 560 271-002



2000

8SB 003 978-001



182x367

2100

18-22

9EY 125 314-001



8SB 003 978-041



182x367

2200

18-22

9MX 127 585-002



8HS 562 691-002



18-22

8KA 003 806-001



2000





Neoplan

Buses

Buses, e.g.
 Cityliner N 116
 Spaceliner N 117/3
 Skyliner N 122/3
 Jetliner N 208
 Airport service bus
 N 940
 Metroliner N 4008
 Low-platform busses
 N 4009, N 4021
 SG, Transliner K

74->



8SB 501 156-031



9MX 561 891-001



8KA 500 218-002



186x375

2200

15-20

1150

8SB 501 190-082



9MX 562 159-023



8KA 562 422-002



8KA 562 423-002



227x434

2100

18-22



Neoplan

Buses

Buses, e.g.
 Cityliner N 116
 Spaceliner N 117/3
 Skyliner N 122/3
 Jetliner N 208
 Airport service bus
 N 940
 Metroliner N 4008
 Low-platform busses
 N 4009, N 4021
 SG, Transliner K

74->



8SB 501 191-202
 9MX 562 159-013
 8KA 562 422-002
 8KA 562 423-002



197x375

2100

18-22



Buses
 Cityliner N, H
 Jetliner N, H, SHD
 Megaliner
 Skyliner
 Spaceliner
 Transliner, K, Ü, L, SHD

8SB 501 247-803



2100











Neoplan					
Buses Buses Cityliner N, H Jetliner N, H, SHD Megaliner Skyliner Spaceliner Transliner, K, Ü, L, SHD	8SB 501 602-812		1800, 240		
	8SB 501 602-822		2100, 450, 240		
Buses, e.g. Jetliner N, H, SHD Transliner, K, Ü, L, SHD	8SB 501 246-822		2100		
	8SB 501 246-812		2100		

Neoplan						
<p>Buses Buses, e.g. Jetliner N, H, SHD Transliner, K, Ü, L, SHD</p> 	8SB 501 246-834			2100, 450		
	8SB 501 246-803			2100, 450		















Neoplan					
Buses Buses, e.g. Jetliner N, H, SHD Transliner, K, Ü, L, SHD	8SB 501 246-902			2100, 240	
	8SB 501 246-892			2100, 450, 240	



Neoplan					
Buses Buses Centroliner Cityliner N, H Skyliner Spaceliner Starliner	8SB 501 247-812			2100	
Buses Cityliner Skyliner Starliner Spaceliner	8SB 501 311-812			2100, 240	

Neoplan								
Buses Buses Cityliner N, H Megaliner Skyliner Spaceliner	8SB 501 311-842			2100, 240				
Buses	8SB 501 247-842			2100				
Nissan								
Patrol	8SB 004 288-001			157x244	2100	10		

Scania							
Buses							
	8SB 501 247-803				2100		
	8SB 501 311-842				2100, 240		
Trucks							
	8SB 003 978-001		182x367	2100	18-22		
	9EY 125 314-001						
	8SB 003 978-041		182x367	2200	18-22		
	9MX 127 585-002						
	8HS 562 691-002					18-22	
	8KA 003 806-001			2000			

Sisu						
Trucks 06/85-> 	8SB 003 290-001 9EY 120 010-001		187x382	2100	14-18	
Steyr						
230 G - 300 GD (W 460) 05/79-> 	8SB 003 609-061		138x210	1400	10	
9 S - 17 S 9 S - 17 S 19 S - 40 S 1291 01/86-> 10/87-> 	8SB 501 081-031 9EY 561 445-001		200x422	2200	18	





















Steyr								
<p>9 S - 17 S 9 S - 17 S 19 S - 40 S 1291</p> 	<p>01/86-> 10/87-></p>	<p>8SB 003 978-001 9EY 125 314-001 8SB 003 978-041 9MX 127 585-002 8HS 562 691-002 8KA 003 806-001</p>	     	<p>182x367 182x367 2000</p>	<p>2100 2200</p>	<p>18-22 18-22 18-22</p>		
Temsa								
Buses								
		<p>8SB 501 246-822</p>	  		<p>2100</p>			
		<p>8SB 501 246-902</p>	  		<p>2100, 240</p>			

Van Hool					
Acron, Alizee Acron, Alizee, Astromega, Astron 	8SB 003 978-001		182x367	2100	18-22
	9EY 125 314-001				
	8SB 003 978-041		182x367	2200	18-22
	9MX 127 585-002				
	8HS 562 691-002				18-22
	8KA 003 806-001		2000		
Buses 	8SB 501 081-031		200x422	2200	18
	9EY 561 445-001				
	8SB 501 602-812			1800, 240	
	8SB 501 602-822			2100, 450, 240	

Van Hool						
Buses	8SB 501 246-812				2100	
	8SB 501 247-803				2100	
	8SB 501 247-812				2100	

Van Hool					
Buses	8SB 501 311-812			2100, 240	
VARIOmobil					
Travel mobil	8SB 501 247-882			2100	

Volkswagen						
LT I LT I all models with M-equipment LT I 35 D - 45 D LT I 50 D LT I 28	04/75->	8SB 560 991-012		186x320	2200	16-18
		9EY 561 042-002				
		8KA 560 271-002		2000		
	08/83->	8SB 560 991-041		186x320	2200	16-18
	90->	9MX 561 044-002				
		8KA 560 271-002		2000		
		8SB 501 045-002		165x255	2200	18-22
		8HS 562 691-002				18-22
		8SB 501 045-012		165x255	2200	18-22
		8HS 562 691-002				18-22
LT II LT II Van (1980 mm vehicle width)	10/95->	8SB 507 042-001		177x283	2000	
		9MX 564 232-001				
		8SB 507 043-001		177x283	2000	
		9MX 564 233-001				
		8SB 507 042-011		177x283	2000	
		9MX 564 232-011				
		8SB 507 043-011		177x283	2000	
		9MX 564 233-011				

Volkswagen							
<p>LT II LT II Platform truck (2150 mm vehicle width)</p> <p>10/95-></p> 	<p>8SB 507 042-021</p> <p>9MX 564 232-001</p> <p>8SB 507 043-021</p> <p>9MX 564 233-001</p> <p>8SB 507 042-031</p> <p>9MX 564 232-011</p> <p>8SB 507 043-031</p> <p>9MX 564 233-011</p>	       	<p>177x283</p> <p>2000</p> <p>177x283</p> <p>2000</p> <p>177x283</p> <p>2000</p> <p>177x283</p> <p>2000</p>	<p>2000</p> <p>2000</p> <p>2000</p> <p>2000</p> <p>2000</p> <p>2000</p> <p>2000</p>			
<p>LT II Platform truck (2300 mm vehicle width)</p> <p>10/95-></p> 	<p>8SB 507 042-041</p> <p>9MX 564 232-001</p> <p>8SB 507 043-041</p> <p>9MX 564 233-001</p> <p>8SB 507 042-051</p> <p>9MX 564 232-011</p> <p>8SB 507 043-051</p> <p>9MX 564 233-011</p>	       	<p>177x283</p> <p>2000</p> <p>177x283</p> <p>2000</p> <p>177x283</p> <p>2000</p> <p>177x283</p> <p>2000</p>	<p>2000</p> <p>2000</p> <p>2000</p> <p>2000</p> <p>2000</p> <p>2000</p> <p>2000</p>			
<p>Transporter (T2)</p> 	<p>8SB 002 407-001</p>		<p>124x192</p> <p>1400</p>	<p>10-12</p>			

Volvo							
Buses		8SB 501 246-822				2100	
		8SB 501 246-892				2100, 450, 240	
Trucks		8SB 003 978-001		182x367	2100	18-22	
		9EY 125 314-001					
		8SB 003 978-041		182x367	2200	18-22	
		9MX 127 585-002					
		8HS 562 691-002					18-22
	8KA 003 806-001			2000			

Volvo					
F 7, F 10, F 12, F 16 12/77-> 	8SB 003 290-001	187x382	2100	14-18	
	9EY 120 010-001				
	8SB 003 290-011	187x382	2100	16-18	
	9MX 560 096-002				
	8KA 560 271-002	2000			
FH 12, FH 16 08/93->12/01 	9MX 564 239-001	175x181	450		
	9MX 564 239-011	175x181	450		
	8SB 354 506-801	440x469	2000		
	8HG 863 841-001				
	8SB 863 843-001				
	9MN 863 849-001				
	9MX 564 214-012				
	9MX 564 215-012				
	8SB 354 506-811	440x469	2000		
	8HG 863 842-001				
	8SB 863 844-001				
	9MN 863 849-001				
	9MX 564 214-012				
9MX 564 215-012					



Volvo

FM

FM 10, FM 12

08/98->12/01



8SB 354 506-801



440x469

2000

8HG 863 841-001



8SB 863 843-001



9MN 863 849-001



9MX 564 214-012



9MX 564 215-012



8SB 354 506-811



440x469

2000

8HG 863 842-001



8SB 863 844-001



9MN 863 849-001



9MX 564 214-012



9MX 564 215-012





Außenspiegel für Land- und Baumaschinen

80 - 81

External mirrors for agricultural and construction machinery

Rétroviseurs extérieurs pour machines agricoles et engins de chantiers

Retrovisores exteriores para máquinas agrícolas y maquinarias para obras

Specchi per macchine agricole- e movimento terra

Spiegels voor landbouwmachines

Universalspiegel

82 - 87

Universal mirrors

Rétroviseurs extérieurs

















Retrovisores exteriores universales

Specchi universali

Universel spiegels

External mirrors for agricultural and construction machinery



					
	8HG 501 430-802	   	200x422	2200	
	8HG 501 430-812	   	200x422	2200	
	8SB 501 081-031	   			
	9EY 561 445-001	 			
	8SB 501 156-021	  	186x375	2200	15-20
	9EY 120 010-001	 			
	8SB 501 156-031	   	186x375	2200	15-20
	9MX 561 891-001	  			
	8KA 500 218-002	  	1150		
	8SB 501 147-003	   	211x161	450	18-22
	9EY 561 814-001	 			
	8SB 003 290-001	  	187x382	2100	14-18
	9EY 120 010-001	 			
	8SB 003 290-011	  	187x382	2100	16-18
	9MX 560 096-002	  			
	8KA 560 271-002	 	2000		
	8SB 002 995-001	  	158x241	2200	
	8SB 002 995-011	  	158x241	2200	

	8SB 560 991-012		186x320	2200	16-18
	9EY 561 042-002				
	8KA 560 271-002		2000		
	8SB 560 991-041		186x320	2200	16-18
	9MX 561 044-002				
	8KA 560 271-002		2000		
	8SB 003 609-061		138x210	1400	10
	8SB 004 288-001		157x244	2100	10
	8SB 004 288-103		157x244	2100	10
	8KA 003 806-001		2000		
	8SB 002 407-001		124x192	1400	10-12
	8SB 002 993-001		180x260	1400	15
	9EY 117 125-001				

	8SB 501 431-811		269x1230	1800, 300, 200	
	8SB 501 431-821		269x1230	1800, 300, 200	
	8SB 501 431-831		264x988	1800, 300	
	8SB 501 431-841		264x988	1800, 300	
	8SB 501 431-851		264x988	1800, 200	
	8SB 501 431-861		264x988	1800, 200	
	8SB 501 431-871		259x804	1800	
	8SB 501 431-881		259x804	1800	

Spare parts and accessories for bus mirrors 88-97

	<p>8SB 501 190-082</p> <p>9MX 562 159-023</p> <p>8KA 562 422-002</p> <p>8KA 562 423-002</p>	 	227x434	2100	18-22
	<p>8SB 501 191-202</p> <p>9MX 562 159-013</p> <p>8KA 562 422-002</p> <p>8KA 562 423-002</p>	 	197x375	2100	18-22
	<p>8SB 501 192-002</p> <p>9MX 562 159-052</p> <p>8KA 562 423-002</p>	 	225x310	2100	18-22
	<p>8SB 507 041-011</p> <p>9EY 120 010-001</p>	 	187x376	2000	14-20

	8SB 004 288-001		157x244	2100	10
	8SB 004 288-092		157x244	2100	18
	8SB 501 511-802		205x125	240	18-22
 	8SB 501 346-022		205x125	240	18-22
	8KA 500 218-002		1150		
	8KA 500 229-002		400		
	8HG 501 347-002		202x72		
	8SB 501 346-032		205x125	240	18-22
	8KA 500 218-002		1150		
	8KA 500 229-002		400		
8HG 501 347-002		202x72			

	8SB 002 991-001		210x300	1400	18
	8SB 002 991-081		210x300	1400	18
	9EY 117 126-001				
	8SB 002 991-182		220x310	1400	18
	9EY 117 126-014				
	8SB 501 263-003		230	2200	18-22
	8SB 501 263-014		230x316	2200	18-22
	8SB 501 263-052		230x316	2200	18-22
	9EY 117 126-014				
	8HS 562 691-002				
	8SB 501 047-011		200x280	2100	12
	8SB 501 137-082		157x247	450	
	8SB 501 137-001				

	8SB 002 994-001 9EY 117 127-001	 	160x265	1400	10
	8SB 002 992-001 9EY 111 231-001	 	155x274	1400	15-18
	8SB 002 405-001 9EY 111 231-001	 	155x270	1400	10-12
	8SB 002 405-011 9EY 111 231-001	 	155x270	1400	15-18
	8SB 002 990-001 9EY 117 124-001	 	220x420	1400	18

	8SB 002 997-001		131x186	1400	10
	8SB 002 997-103		131x186	1400	10
	9EY 117 129-001				
	8SB 002 404-121		165x210	1400	10-12
	9EY 111 230-001				
	8SB 002 404-131		165x210	1400	10-12
	9EY 111 230-001				
	8SB 002 406-001		Ø 127		10-12
	8SB 003 212-001		Ø 155	1400	10-12



Ersatzteile und Zubehör für Busspiegel 89 - 97
Spare parts and accessories for bus mirrors
Pièces de rechange et accessoires pour rétroviseurs de cars
Piezas de recambio y accesorios para autocares
Ricambi e accessori per autobus
Onderdelen en toebehoren voor busspiegels

Zubehör 98 - 100
Accessories
Accessoires
Accesorios
Accessori
Onderdelen

Übersichten 101 - 104
Overviews
Listes
Tablas de comparación
Quadri riassuntivi
Overzichten

8SB 501 431-871
8SB 501 431-881

8SB 501 431-851
8SB 501 431-861

8SB 501 431-831
8SB 501 431-841

8SB 501 431-811
8SB 501 431-821



Abb. Illus. Fig. Afb.	Bestell-Nr./Part no./Références/N° de pedido/Codice Hella/Bestelnr.						
1	9MX 562 841-002	Spiegelglasträgergruppe Hauptspiegel	Mirror glass carrier for main mirror	Support à miroir pour rétroviseur principal	Porta-espejo para retrovisor principal	Portaspecchio per specchio principale	Spiegelglashouder voor chauffeursspiegel
2	9MX 564 357-011 9MX 564 357-002	Spiegelglasträgergruppe Weitwinkel-/Bugbeobachtungsspiegel, links rechts	Mirror glass carrier for wide-angle / door observation mirror, left right	Support à miroir pour rétroviseur grand-angle / d'observation à'avant, gauche droit	Porta-espejo para retrovisor panorámico y de observación delantera, izq. der.	Porta specchio per specchio ad ampio raggio e controllo anteriore, sinistro destro	Spiegelglashouder voor groothoekspiegel / frontobservatiespiegel, links rechts
3	9MX 562 846-031	Spiegelglasträgergruppe Weitwinkelspiegel	Mirror glass carrier for wide-angle mirror	Support à miroir pour rétroviseur grand-angle	Porta-espejo para retrovisor panorámico	Porta specchio per specchio ad ampio raggio	Spiegelglashouder voor groothoekspiegel
4	9HD 564 946-002	Abdeckkappe, kurz	Cover, short	Cache, court	Embellecedor, corto	Calotta di chiusura, corto	Afdekkap, kort
5	9HD 564 945-002	lang	long	long	largo	lunghezza	lang

8SB 501 602-... / 8SB 501 246-...

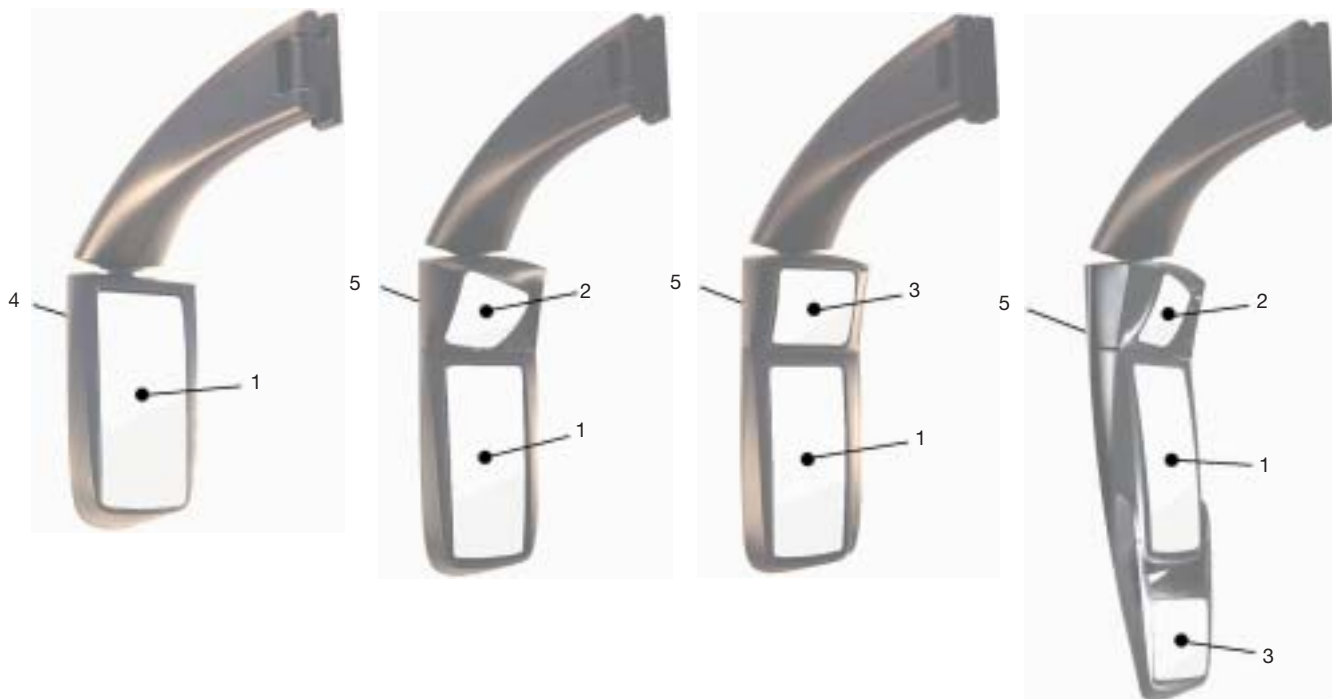

Abb./Illus./Fig./
Fig./Fig./Afb.

Bestell-Nr./Part no./Références/
N° de pedido/Codice Hella/Bestelnr.

1	8HS 563 390-002	
2	9BP 563 482-002	
3	9HD 562 802-012	
4	9XD 562 800-052	
5	9XD 563 637-012	
6	9HB 562 824-022	for 501 246-... (551 mm)
7	9GH 562 803-002	
8	9BG 562 812-002	
9	9BG 562 813-002	
10	9BG 562 814-002	
11	9SV 562 840-003	
12	9MN 562 843-071 9MN 562 843-022	
13	9MX 562 846-002	
14	9MX 562 841-002	
15	9SV 562 829-002	
16	8KB 500 299-251	

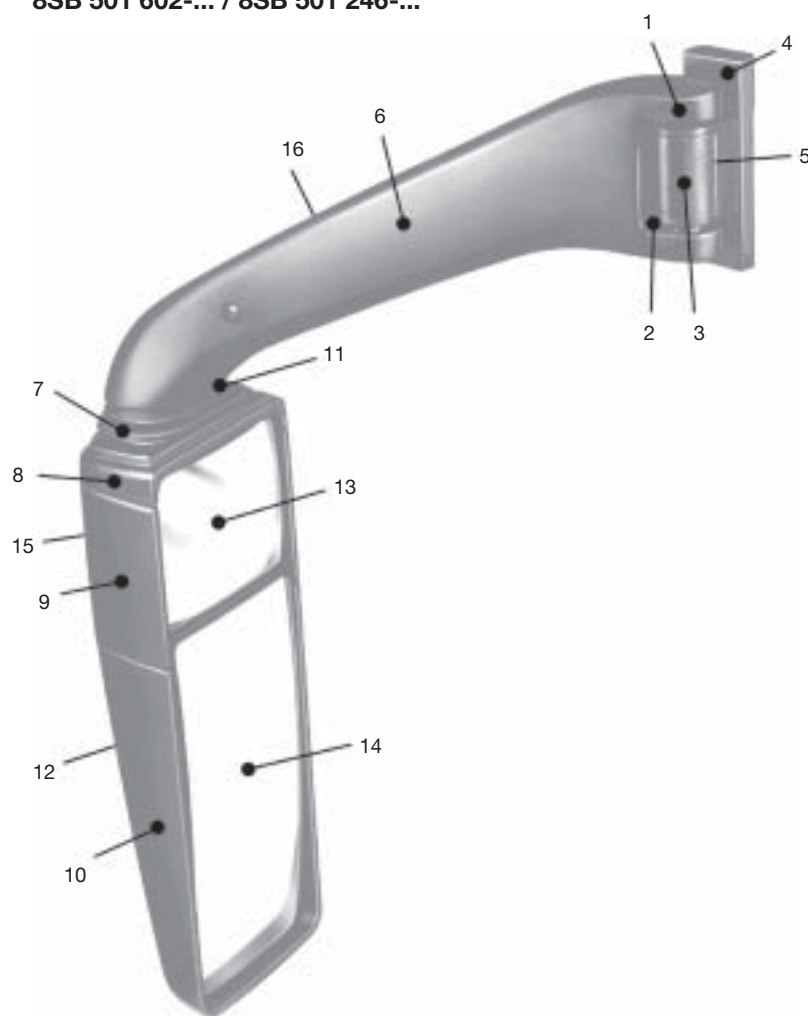

Ersatzteile/Spare parts/Pièces de rechange/ Piezas de recambio/Ricambi/Onderdelen

Abb. Illus. Fig. Afb.	Bestell-Nr./Part no./Références/N° de pedido/Codice Hella/Bestelnr.						
1	8HS 563 390-002	Befestigungsgruppe für Halter	Fastening hardware assembly for holder	Groupe de fixation pour support	Grupo de sujeción para soporte	Gruppo di fissaggio per supporto	Bevestigingsgroep voor houder
2	9BP 563 482-002	Stützhaltergruppe	Support holder assembly	Groupe support de soutien	Grupo soporte de apoyo	Gruppo supporto d'appoggio	Arm
3	9HD 562 802-012	Abdeckkappe	Cover	Cache	Cubierta	Calotta di chiusura	Afdekkap
4	9XD 562 800-052	Halter	Holder	Support	Soporte	Supporto	Houder
5	9XD 563 637-012	Haltermontagegruppe	Holder assembly	Elément support pour fixation sur carrosserie	Grupo de montaje del soporte	Gruppo montaggio supporto	Montageset voor houder
6	9HB 562 824-022	Armverkleidungsgruppe	Arm cover assembly	Groupe d'habillage de bras	Grupo revestimiento del brazo	Gruppo rivestimento braccio	Bekledingsschalen voor arm
7	9GH 562 803-002	Faltenbalg	Bellows	Soufflet	Fuelle	Manicotto a soffietto	Balg
8	9BG 562 812-002	Gehäuseoberteil	Housing upper support	Partie supérieure du boîtier	Parte superior de la carcasa	Carcassa, parte superiore	Spiegelhuis, bovenste deel
9	9BG 562 813-002	Gehäusemittelteil	Housing centre support	Partie centrale du boîtier	Parte central de la carcasa	Carcassa, parte mediana	Spiegelhuis, middelste deel
10	9BG 562 814-002	Gehäuseunterteil	Housing bottom support	Partie inférieure du boîtier	Parte inferior de la carcasa	Carcassa, parte inferiore	Spiegelhuis, onderste deel
11	9SV 562 840-003	Kalottenmontagegruppe	Cap mounting assembly	Groupe de mont. de la calotte	Grupo de montaje de calotas	Gruppo montaggio calotta	Bevestigingsgroep voor spiegelkop
12	9MN 562 843-071 9MN 562 843-022	Verstellantrieb, 12V 24V	Adjustment drive, 12V 24V	Commande de réglage, 12V 24V	Aparato regulador, 12V 24V	Dispositivo di regolazione, 12V 24V	Verstelaandrijving, 12V 24V
13	9MX 562 846-002	Spiegelglasträgergruppe Weitwinkelspiegel, 24V	Mirror glass carrier assembly for wide-angle mirror, 24V	Groupe support de miroir pour rétroviseur grand-angle, 24V	Grupo porta-espejo retrovisor panorámico, 24V	Gruppo portaspecchio ad ampio raggio, 24V	Spiegelglashoudergroep voor groothoekspiegel, 24V
14	9MX 562 841-002	Spiegelglasträgergruppe Hauptspiegel, 24V	Mirror glass carrier assembly for main mirror, 24V	Groupe support de miroir pour rétroviseur principal, 24V	Grupo porta-espejo retrovisor principal, 24V	Gruppo portaspecchio principale, 24V	Spiegelglashoudergroep voor chauffeursspiegel, 24V
15	9SV 562 829-002	Verstellgerät TIP-TAP für Weitwinkelspiegel 8SB 501 246-803/-834/-892	TIP-TAP adjusting device for wide-angle mirror 8SB 501 246-803/-834/-892	Appareil de réglage TIP-TAP pour rétroviseur grand-angle 8SB 501 246-803/-834/-892	Aparato regulador TIP-TAP para retrovisor panorámico 8SB 501 246-803/-834/-892	Dispositivo di regolazione TIP-TAP per ad ampio raggio 8SB 501 246-803/-834/-892	Versteltoestel TIP-TAP voor groothoekspiegel 8SB 501 246-803/-834/-892
16	8KB 500 299-241	Leitungsgruppe, 6-polig, 940 mm	Cable assembly, 6-pole, 940 mm	Groupe câble de connexion, 2 pôles, 940 mm	Grupo cable de conexión de 6 polos, 940 mm	Gruppo cavo di connessione a 6 poli, 940 mm	Aansluitkabelgroep, 6-polig, 940 mm

8SB 501 247-... / 8SB 501 311-...



Abb./Illus./Fig./
Fig./Fig./Afb.

Bestell-Nr./Part no./Références/
N° de pedido/Codice Hella/Bestelnr.

1	9HB 562 837-022	
2	9GH 562 803-002	
3	9BG 562 812-002	
4	9BG 562 813-002	
5	9BG 562 814-002	
6	9MN 562 843-051	
	9MN 562 843-011	
7	9HD 562 802-012	
8	9MX 562 846-002	
	9MX 562 846-002	
9	9MX 562 841-002	24V
	9MX 562 841-012	12V
10	8HG 562 851-002	24V
	8HG 562 851-012	12V
11	9SV 562 829-002	
12	9SV 562 840-003	

Abb. Illus. Fig. Afb.	Bestell-Nr./Part no./Références/N° de pedido/Codice Hella/Bestelnr.						
1	9HB 562 837-022	Armverkleidungsgruppe (2 Halbschalen)	Arm cover assembly (2 half shells)	Groupe d'habillage de bras (2 demi-coques)	Grupo revestimiento del brazo (2 medias carcasas)	Gruppo rivestimento braccio (2 semicoppe)	Bekledingsschalen voor spiegelarm (2 stuks)
2	9GH 562 803-002	Faltenbalg	Bellows	Soufflet	Fuelle	Manicotto a soffietto	Balg
3	9BG 562 812-002	Gehäuseoberteil	Housing upper section	Partie supérieur du boîtier	Parte superior de la carcasa	Carcassa, parte superiore	Spiegelhuis, bovenste deel
4	9BG 562 813-002	Gehäusemittelteil	Housing centre section	Partie centrale du boîtier	Parte central de la carcasa	Carcassa, parte mediana	Spiegelhuis, middelste deel
5	9BG 562 814-002	Gehäuseunterteil	Housing bottom section	Partie inférieure du boîtier	Parte inferior de la carcasa	Carcassa, parte inferiore	Spiegelhuis, onderste deel
6	9MN 562 843-051	Verstellantrieb, 12V	Adjustment drive, 12V	Commande de réglage, 12V	Aparato regulador, 12V	Dispositivo di regolazione, 12V	Verstelaandrijving, 12V
	9MN 562 843-011	24V	24V	24V	24V	24V	24V
7	9HD 562 802-012	Abdeckkappe	Cover	Cache	Cubierta	Calotta di chiusura	Afdekkap
8	9MX 562 846-002	Spiegelglasträgergruppe Weitwinkelspiegel, 24V	Mirror glass assembly for wide-angle mirror, 24V	Groupe support de miroir pour rétroviseur grand-angle, 24V	Grupo porta-espejo retrovisor panorámico, 24V	Gruppo portaspecchio ad ampio raggio, 24V	Spiegelglashoudergroep voor groothoekspiegel, 24V
	9MX 562 846-012	12V	12V	12V	12V	12V	12V
9	9MX 562 841-002	Spiegelglasträgergruppe Hauptspiegel, 24V	Mirror glass assembly for main mirror, 24V	Groupe support de miroir pour rétroviseur principal, 24V	Grupo porta-espejo retrovisor principal, 24V	Gruppo portaspecchio principale, 24V	Spiegelglashoudergroep voor chauffeursspiegel, 24V
	9MX 562 841-012	12V	12V	12V	12V	12V	12V
10	8HG 562 851-002	Spiegelarmgruppe stehend	Mirror arm assembly upright	Groupe bras de rétroviseur, montage posé	Brazo montaje en posición de pie	Gruppo braccio, ritto	Spiegelarmgroep staand
	8HG 562 851-012	hängend	pendant	montage suspendu	montaje en posición invertida	appeso	hangend
11	9SV 562 829-002	Verstellgerät TIP-TAP für Weitwinkelspiegel	TIP-TAP adjusting device for wide-angle mirror	Appareil de réglage TIP-TAP pour rétroviseur grand-angle	Aparato regulador TIP-TAP para retrovisor panorámico	Dispositivo di regolazione TIP-TAP per specchio ad ampio raggio	Versteltoestel TIP-TAP voor groothoekspiegel
12	9SV 562 840-003	Kalottenmontagegruppe	Cap mounting assembly	Groupe de montage de la calotte	Grupo de montaje de calotas	Gruppo montaggio calotta	Bevestigingsgroep voor spiegelkop

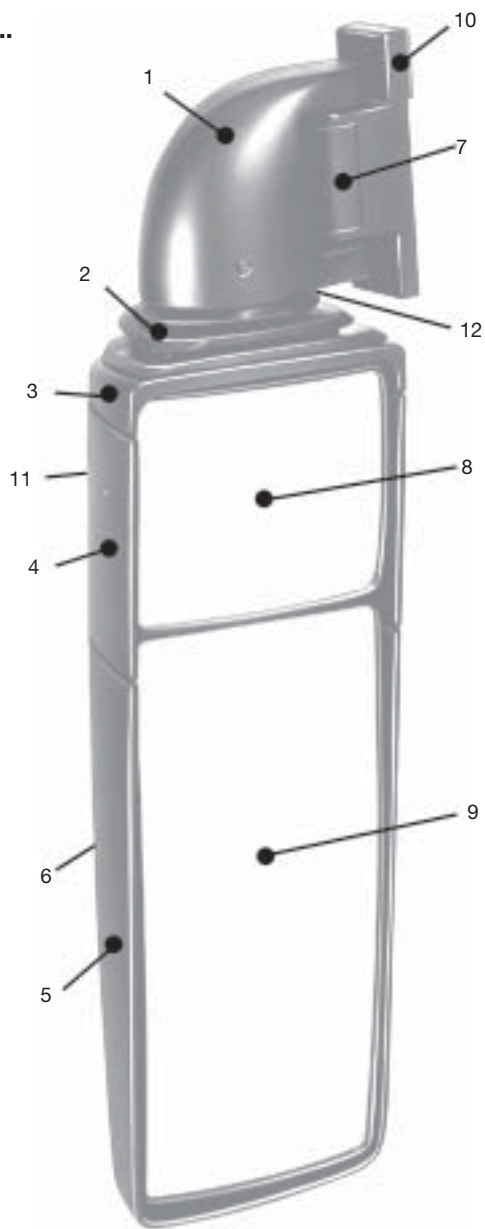
8SB 501 402-... / 8SB 501 403-...



Abb./Illus./Fig./
Fig./Fig./Afb.

Bestell-Nr./Part no./Références/
N° de pedido/Codice Hella/Bestelnr.

1	9XD 564 376-002 9XD 564 384-002
2	9HB 564 365-002 9HB 564 381-002
3	9BP 564 386-002
4	9HB 564 363-002
5	9HB 564 364-002
6	9BG 564 360-002
7	9HD 564 383-002
8	9MN 562 843-002 9MN 562 844-032
9	9MX 564 357-002
10	9MX 564 356-002
11	9GD 564 362-002
12	9SV 562 829-002

Abb. Illus. Fig. Afb.	Bestell-Nr./Part no./Références/N° de pedido/Codice Hella/Bestelnr.						
1	9XD 564 376-002	Spiegelfuß für 501 402-...	Mirror base for 501 402-...	Support de rétroviseur pour 501 402-...	Pie de espejo para 501 402-...	Piede specchio per 501 402-...	Spiegelvoet voor 501 402-...
	9XD 564 384-002	für 501 403-...	for 501 403-...	pour 501 403-...	para 501 403-...	per 501 403-...	voor 501 403-...
2	9HB 564 365-002	Spiegelfuß-verkleidung für 501 402-...	Trim for mirror base for 501 402-...	Habillage du support de rétroviseur pour 501 402-...	Revestimiento del pie de espejo para 501 402-...	Rivestimento piede specchio per 501 402-...	Spiegelvoet ommanteling voor 501 402-...
	9HB 564 381-002	für 501 403-...	for 501 403-...	pour 501 403-...	para 501 403-...	per 501 403-...	voor 501 403-...
3	9BP 564 386-002	Stützhaltergruppe	Support bracket assembly	Groupe support	Grupo de soporte de apoyo	Gruppo supporto	Bevestigingsgroep voor drager
4	9HB 564 363-002	Armverkleidungsgruppe, oben	Arm cover assembly above	Groupe d'habillage de bras, haut	Revestimiento del brazo, superior	Gruppo rivestimento braccio, parte superiore	Spiegelarm ommanteling, boven
			below				
5	9HB 564 364-002	unten					
6	9BG 564 360-002	Gehäuse	Housing	Boîtier	Carcasa	Involucro esterno	Huis
7	9HD 564 383-002	Abdeckkappe	Cover	Cache	Embellecedor	Calotta di chiusura	Afdekkap
8	9MN 562 843-002	Verstellantrieb, 24V	Adjusting, 24V	Commande de réglage, 24V	Ajuste, 24V	Meccanismo regolazione, 24V	Verstelmechanisme, 24V
	9MN 562 844-032	manuell	manually	réglable manuellement	manual	manuale	manueel
9	9MX 564 357-002	Spiegelglasträgergruppe Weitwinkelspiegel, 24V	Mirror glass carrier for wide-angle mirror, 24V	Support à miroir pour rétroviseur grand-angle, 24V	Porta-espejo para retrovisor panorámico, 24V	Porta specchio per specchio ad ampio raggio, 24V	Spiegelglashouder voor groothoekspiegel, 24V
10	9MX 564 356-002	Spiegelglasträgergruppe Hauptspiegel, 24V	Mirror glass carrier for main mirror, 24V	Support à miroir pour rétroviseur principal, 24V	Porta-espejo para retrovisor principal, 24V	Porta specchio per specchio principale, 24V	Spiegelglashouder voor chauffeursspiegel, 24V
11	9GD 564 362-002	Blende	Trim	Enjoliveur	Cubierta	Mascerina	Plaat
12	9SV 562 829-002	Verstellgerät TIP-TAP für Einstieg-/Bugbeobachtungsspiegel	TIP-TAP adjusting device for front end-/door observation mirror	Appareil de réglage TIP-TAP pour rétroviseur d'accès et d'observation à lavant	Aparato regulador TIP-TAP para retrovisor panorámico y de observación delantera	Dispositivo di regolazione TIP-TAP per specchio di salita/controllo anteriore	Versteltoestel TIP-TAP voor instap-/front-observatiespiegel

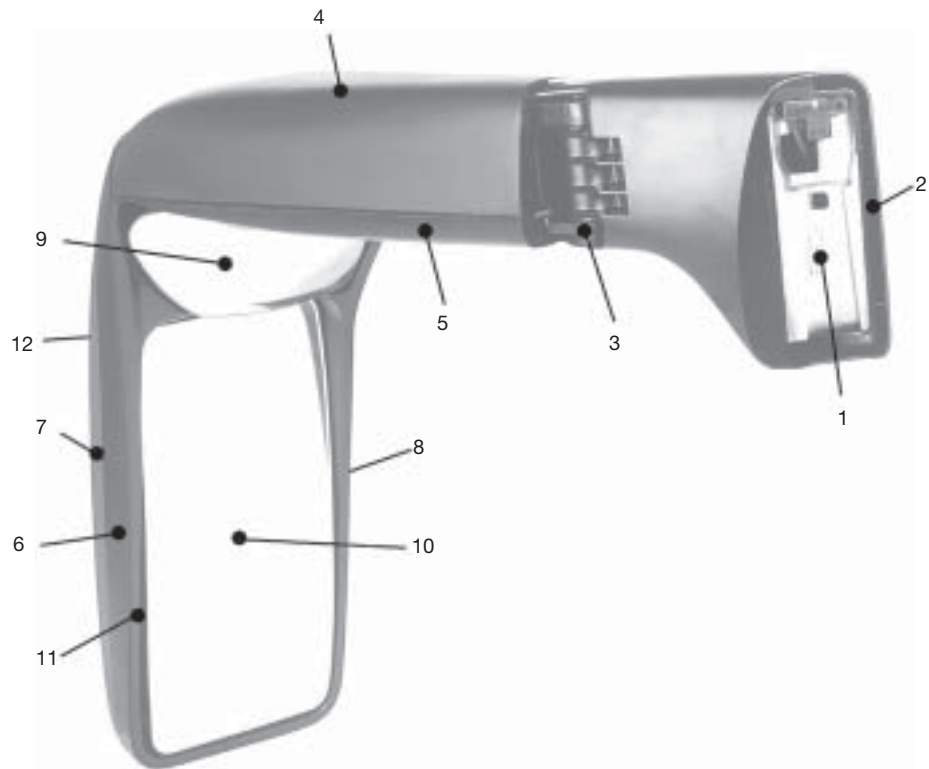
8SB 501 401-...



Abb. Illus. Fig. Afb.	Bestell-Nr./Part no./Références/N° de pedido/Codice Hella/Bestelnr.						
1	9MX 564 305-002	Spiegelglasträger, 24V	Mirror glass carrier, 24V	Support à miroir, 24V	Porta-espejo, 24V	Portaspecchio, 24V	Spiegelglashouder, 24V
2	9HD 564 310-002	Spiegelgehäuse	Mirror housing	Boîtier de rétroviseur	Carcasa del espejo	Carcassa	Spiegelhuis
3	9MN 562 843-002 9MN 562 844-032	Verstellantrieb, 24V manuell	Adjustment drive, 24V manual	Dispositif de réglage, 24V manuel	Ajuste eléctrico, 24V manual	Meccanismo regolazione, 24V manuale	Verstelmechanisme, 24V manueel
4	9HD 564 316-002	Abdeckkappe	Cover	Cache	Cubierta	Calotta di chiusura	Afdekkap
5	9GD 564 312-002	Blende	Trim	Enjoliveur	Embellecedor	Mascherina	Plaat
6	9XD 564 323-002	Klappscharnier	Folding hinge	Charnière rabattable	Bisagra de abatimiento	Cerniera	Klappscharnier



	7-pole		
9BP 501 237-002			X = 5 / 2500
9BP 501 237-012			X = 5 / 2500
9BP 501 238-002			X = 0 / 2500
9BP 501 238-012			X = 0 / 4000
9BP 501 238-022			X = 0 / 5500
9BP 561 006-012			
9BP 561 138-052	2-pole		2000
9BP 561 138-013	2-pole		1500
9XD 563 637-012	For 8SB 501 246-..., 8SB 501 311-..., 8SB 501 420-..., 8SB 501 602-... 		
6GM 500 212-012	12V		
6GM 500 212-002	24V		
8JA 500 431-002	Sammelstecker, 7-polig Common plug, 7-pole Connecteur, 7 pôles Conector colector, 7 polos Attacco centralizzato, a 7 poli Verzamelstekker voor dubbelschakelaar, 7-polig		

	<p>8KA 562 671-002</p>		2500	
	<p>8KA 500 229-002</p>		400	
	<p>8KA 500 218-002</p>		1150	
	<p>8HG 003 323-032</p>	<p>schwarz/black/noir/ negro/nero/zwart</p>	18	
	<p>8HG 003 323-112</p>	<p>schwarz/black/noir/ negro/nero/zwart</p>	18	
	<p>8HG 002 211-001</p>	<p>verzinkt/galvanized/galvanisée/ galvanizado/zincato/gegalvaniseerd</p>	12	
	<p>8HG 561 107-112</p> <p>9BP 561 138-013</p> <p>9BP 561 138-052</p>	<p>2-pole</p> <p>schwarz/black/noir/ negro/nero/zwart</p> <p>2-pole</p> <p>2-pole</p>	18	1500
			2000	

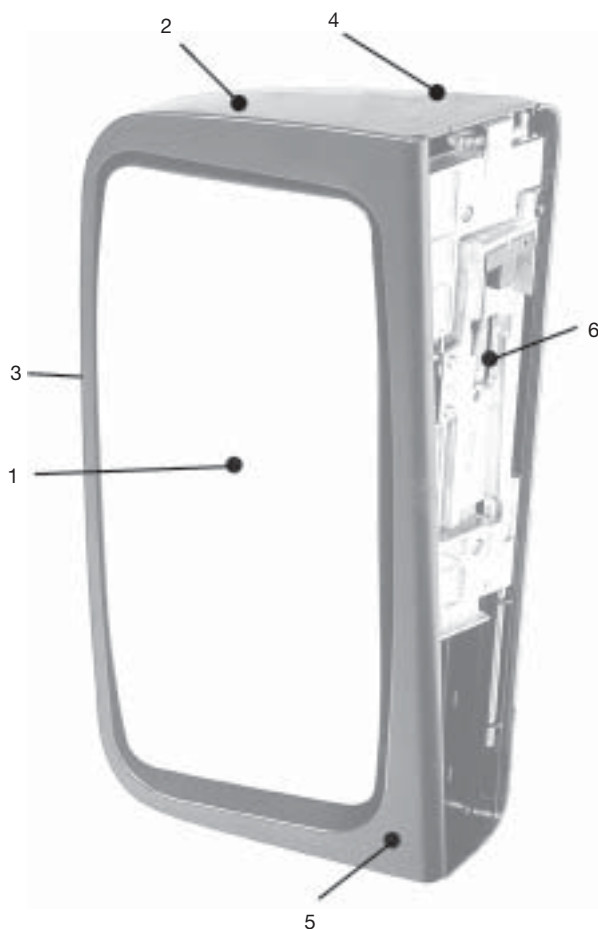
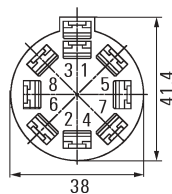
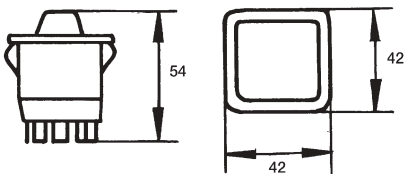
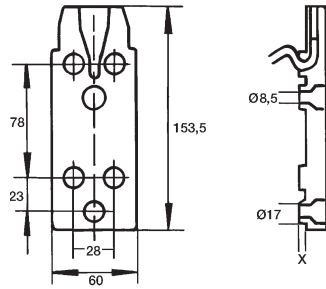
	<p>8HG 561 108-002</p> <p> </p> <p>schwarz/black/noir/ negro/nero/zwart</p>			18
	<p>8HG 501 255-012</p> <p> </p> <p>8HG 501 255-022</p> <p> </p> <p>schwarz/black/noir/ negro/nero/zwart</p>			22
	<p>8HG 501 067-002</p> <p> </p>			18
	<p>8HG 501 101-002</p> <p> </p> <p>schwarz/black/noir/ negro/nero/zwart</p>			18
	<p>8HG 501 253-002</p> <p> </p>			22

	<p>8HG 501 253-012</p> <p>8HG 501 253-022</p> <p>schwarz/black/noir/ negro/nero/zwart</p> <p>9BP 563 035-002</p> <p>9BP 563 036-002</p>			<p>22</p> <p>22</p>
	<p>8HG 501 253-052</p>			<p>22</p>
	<p>8HG 501 257-002</p> <p>9BP 563 037-002</p>			<p>22</p>
	<p>8HG 501 257-032</p> <p>8HG 501 257-042</p> <p>9BP 563 038-012</p> <p>9BP 563 039-012</p>			<p>22</p> <p>22</p>
	<p>8HG 501 266-022</p> <p>8HG 501 266-032</p>			<p>22</p> <p>22</p>



Albert	Hella	Claas	Hella	Evobus	Hella	Herth & Buss	Hella
766.1	9EY 117 125-001	037 272 80	8SB 002 994-001	000 811 04 25	9XD 564 376-002	79 382 221	9MX 564 233-001
769.1	9EY 120 010-001	682 146 0	8SB 002 991-001	000 811 04 60	9HB 564 365-002	79 382 222	9MX 564 232-011
771.1	9EY 117 126-001	DAF	Hella	000 811 05 60	9HB 564 381-002	79 382 223	9MX 564 233-011
771.11	8SB 002 991-001	142 5105	8SB 354 507-001	000 811 05 61	9HD 564 383-002	79 382 230	9MX 564 214-012
772.1	9EY 117 127-001	142 5108	8SB 354 508-001	000 811 06 60	9BG 562 812-002	79 382 231	9MX 564 215-012
785.12	8SB 003 609-011	142 5111	9MX 863 846-001	000 811 06 61	9HD 564 316-002	79 382 232	9MX 564 239-001
787.1	9EY 111 231-001	142 5113	9HB 863 833-001	000 811 07 60	9BG 562 814-002	79 382 531	9MX 560 096-002
78.711	8SB 002 405-001	142 5114	9HB 863 834-001	000 811 08 60	9HB 562 837-022	79 382 531	9MX 561 891-001
792.1	9EY 122 979-001	161 0184	8SB 354 507-001	000 811 09 60	9BG 564 360-002	79 382 551	9MX 561 449-001
792.12	8SB 003 614-001	161 0187	8SB 354 508-001	000 811 10 61	9HD 562 802-012	Holder	Hella
792.12H	8SB 003 614-081	650 361	8SB 354 508-001	000 811 15 60	9BG 562 813-002	141334	8SB 004 288-103
793.1	9EY 125 314-001	0067 657	8SB 003 978-041	000 811 20 33	9EY 561 042-002	141335	8KA 003 806-001
793.12	8SB 003 978-001	006 7658	9EY 125 314-001	000 811 24 33	9EY 561 814-001	Ikarus	Hella
793.12H	8SB 003 978-041	006 7659	9MX 127 585-002	000 811 80 33	8SB 501 081-082	70003-12001	6GM 500 212-002
909.1	9EY 561 042-002	006 7660	9MX 561 449-001	8.688.074.000 0	Faun	70003-46801	8SB 501 246-803
970.12H	8SB 501 081-041	086 7555	9MX 561 890-001	2647-232	Hella	70003-46811	8SB 501 246-812
Becker Group	Hella	892 893	8SB 002 995-041	4200-425	8SB 002 406-001	70003-46821	8SB 501 246-822
1010503	9EY 117 124-001	089 2894	8SB 501 147-021	772 36 11	8HG 002 211-001	70003-47811	8SB 501 247-812
1010505	9EY 120 010-001	892 895	8SB 501 147-031	772 36 17	8SB 003 978-041	Iveco	Hella
1010508	9EY 561 042-002	892 896	8SB 003 978-001	FENDT	8SB 003 978-041	237 6392KZ1210-67	8SB 002 991-001
101A005	9MX 560 096-002	892 897	8SB 003 978-041	1 828 002 005 70	8SB 002 997-001	2601417	8SB 003 290-001
1110051	9EY 122 979-001	892 898	8SB 501 081-031	7 101 002 5	8HG 002 211-001	262 8194	9EY 120 010-001
1110063	8SB 003 609-011	Deere, John	8SB 501 081-041	7 101 062 4	8SB 002 406-001	4220 9371	9MX 560 096-002
1110065	8SB 003 614-001	Hella	Hella	7 111 004 5	8SB 002 407-011	422 09394	9EY 125 314-001
1110067	8SB 003 978-001	AZ 23 981	8SB 002 990-001	7 195 902 8	8HG 002 211-001	422 09401	9EY 125 314-001
1110068	8SB 003 978-041	23 93 69	9EY 117 124-001	8 110 004 1	8SB 002 994-001	432 5557KZ1024-67	8SB 003 978-041
1110072	9EY 125 314-001	Deutz-Fahr	Hella	G 817 814 10	8SB 002 406-001	8600 3144	8SB 002 997-001
1110077	8SB 002 995-041	160 56743	6GM 500 212-002	G 810 010 150 010	8SB 002 406-001	Jungheinrich	Hella
1110078	8SB 002 995-041	0650 5105 KB 6107G05	8SB 003 290-001	G 297 810 150 030	8HG 501 253-002	26918768	8SB 002 997-001
1110121	8SB 003 609-061	000 9941016	8SB 002 406-001	G 515 810 150 010	8SB 501 263-014	27827700	8SB 002 407-001
1110124	8SB 004 288-001	000 9941300	8HG 002 211-001	Fiat	8HG 501 253-052	440072635	8SB 002 407-001
1110125	8SB 501 081-031	Ernst Auwärter	Hella	4982226	Hella	440072635	8SB 002 407-011
1110126	8SB 501 081-041	1905.567.00	8SB 501 247-842	4982226	8SB 002 407-011	Kässbohrer	Hella
1110505	9EY 561 445-001	1905.581.00	8SB 501 247-803	71010025	8SB 003 609-061	8.919.926.285.4	9MX 563 468-002
1110506	8SB 003 614-001	1905.591.00	8SB 501 246-812	71010624	8HG 002 211-001	8.919.931.924.4	8SB 501 311-824
1110507	8SB 003 978-001	1905.592.00	8SB 501 246-822	71959028	8SB 002 406-001	Kromberg	Hella
1110508	8SB 003 978-041	1905.593.00	8SB 501 246-803	Ford	8SB 002 994-001	055553	8JA 500 431-002
1110513	8SB 501 081-031	1905.594.00	8SB 501 246-834	7 384 397	8SB 002 405-011	Liebherr	Hella
1110514	8SB 501 081-041	1905.595.00	8SB 501 311-812	73 882 211	8SB 002 407-011	1 002 033 8	8SB 501 137-082
1110516	9EY 122 979-001	1905.595.50	8SB 501 311-842	73 882 211	8SB 002 407-011	1 002 043 3	8SB 501 325-002
1110517	9EY 125 314-001	1905.596.00	8SB 501 247-812	86 010 491	8SB 002 995-041	10098664	8KA 562 671-002
1110518	9EY 561 445-001	1905.604.00	8SB 501 246-892	95CT 17K706AA	8SB 004 286-103	5 915 519 08	8SB 501 147-001
1310010	8SB 002 407-011	1905.605.00	8SB 501 246-892	V96CT17K706AA	8SB 501 156-031	5 915 945 14	8HG 002 211-001
2120001	9EY 117 125-001	1905.606.00	8SB 501 246-902	V98CT17K706AA	8SB 501 147-031	7 790 022 14	8SB 501 081-031
2120003	8SB 003 290-001	1905.606.50	8SB 501 602-812	YC4417K706EA	Hella	7 790 024	8SB 002 404-121
2120006	9EY 120 010-001	1906.606.10	8KB 500 299-251	Frese	9EY 111 230-001	7 790 024	8SB 002 404-131
2120013	8SB 002 407-011	341-AS010	8SB 501 511-802	0.227/6	8SB 002 992-001	7 790 283 14	8SB 002 997-001
2120014	9EY 120 010-001	341-AS013	8SB 501 247-803	30.770/6	Hella	7 790 285 14	9BP 561 006-012
5610146	9EY 117 127-001	341-ASH014	8SB 501 246-812	Fritzmeier	220 522	MAN	6GM 500 212-002
5610219	8SB 002 991-001	341-ASH015	8SB 501 246-822	220 522	662 920	152 00 77 0702	9MX 127 585-002
5610343	8SB 002 994-001	341-ASH016	8SB 501 246-834	Hagus	Hella	161 00 77 0701	9EY 117 126-014
5610399	9EY 117 129-001	341-ASH017	8SB 501 246-892	5104	8SB 003 609-011	81.63700.6087	8KA 560 271-002
5610405	8SB 003 609-011	341-ET005	6GM 500 212-002	5115	8SB 003 978-001	81.63700.6088	8SB 501 246-822
5610499	8SB 003 609-061	341-GP004	9BP 501 238-012	5116	8SB 003 978-041	81.63700.6089	8SB 501 246-803
5610502	8SB 560 991-012	341-GP004	9BP 561 138-013	5122	8SB 003 614-001	81.63700.6090	8SB 501 247-803
561 0515	8SB 002 995-011	341-HS025	9XD 563 637-012	5123	8SB 003 614-011	81.63730.0032	9MX 561 891-001
561 0516	8SB 003 614-001	341-KS003	8KA 560 271-002	5175	8SB 501 081-031	81.63730.0065	9MX 561 891-001
561 0518	8SB 002 407-011	341-KS005	8KA 500 218-002	9617	9EY 125 314-001	81.63730.0066	9BG 562 812-002
561 0519	8SB 003 290-001	341-KS005	9MX 562 841-002	9620	9EY 561 042-002	81.63730.0067	9BG 562 813-002
561 0520	8SB 003 290-011	341-SG002	8SB 501 137-031	9621	9EY 120 010-001	81.63730.0067	9BG 562 814-002
561 0534	8SB 002 995-011	629-IS008	Evobus	9623	9EY 122 979-001	81.63730.6003	9MX 561 891-001
561 0539	8SB 003 978-001	Hella	001 810 21 16	9624	9MX 127 586-001	81.63730.6007	8SB 002 993-001
561 0540	8SB 003 978-041	8SB 003 978-041	001 810 23 16	9625	9MX 127 585-002	81.63730.6027	8SB 501 047-011
561 0561	8SB 004 288-001	8SB 003 978-041	001 810 24 16	9627	9MX 560 096-002	81.63730.6106	8SB 002 405-001
561 0568	8SB 560 991-012	8SB 560 991-012	001 810 29 16	9648	9EY 117 125-001	81.63730.6127	8SB 002 407-011
561 0569	8SB 560 991-041	8SB 560 991-041	001 810 29 16	9672	9EY 561 445-001	81.63730.6127	8SB 560 991-012
561 0573	8SB 003 978-001	8SB 003 978-001	001 810 30 14	9673	9MX 561 449-001	81.63730.6140	8SB 002 990-001
5619347	9EY 111 230-001	9EY 111 230-001	001 811 31 33	Hako	Hella	81.63730.6148	8SB 560 991-041
5619348	9EY 117 126-001	9EY 117 126-001	001 811 42 33	90174897	8SB 003 614-001	81.63730.6167	8SB 560 991-012
Case	Hella	8SB 003 978-041	001 811 43 33	90-29489-3	8SB 501 137-031	81.63730.6187	8SB 002 995-041
1-161-007-707-01	9EY 117 126-014	8SB 004 288-001	001 811 45 33	90-35733-6	8SB 003 614-081	81.63730.6197	8SB 501 137-031
1 31928 A1	8SB 501 263-003	8SB 560 991-012	001 811 46 33	90-35779-9	8KA 003 806-001	81.63730.6202	9MX 560 096-002
1 344063 C1	8SB 004 288-092	8SB 560 991-041	001 811 47 33	90-74077-0	8SB 002 994-001	81.63730.6202	9MX 561 891-001
1-34-577-027	8HG 501 257-002	8SB 002 995-011	001 810 33 16	90799305	8SB 501 147-021	81.63730.6204	8SB 501 081-031
1-34-677-015	8HG 501 255-012	8SB 002 995-011	001 810 39 16	Hanomag	Hella	81.63730.6206	8SB 501 147-021
1-34-677-016	8HG 501 255-022	9EY 122 979-001	001 810 58 16	(Komatsu)	9EY 117 129-001	81.63730.6209	8SB 003 978-041
1-34-677-017	8SB 003 614-001	9MX 563 716-022	001 810 59 16	185 7030 040	8SB 002 992-001	81.63730.6214	8SB 501 137-031
1-34-677-082	8HG 501 257-032	9BP 563 038-012	001 810 84 14	3227 704 M91	8SB 002 992-001	81.63730.6219	8SB 501 156-021
1-34-677-083	8HG 501 257-042	9BP 563 039-012	001 811 23 14	381 8102 616	8SB 003 978-041	81.63730.6221	8SB 501 156-031
1-34-677-1101	8SB 501 263-003	9SG 563 140-002	001 811 30 14	582 9547 09	8SB 002 997-001	81.63730.6222	8SB 501 147-003
1-34-777-001	9EY 561 042-002	9EY 122 979-001	001 811 31 33	595 9751 910	8SB 002 991-001	81.63730.6222	8SB 501 147-021
1-34-777-012	9SG 563 140-002	9EY 122 979-001	001 810 33 16	595 9752 210	8SB 002 991-001	81.63730.6222	9HB 562 837-022
1-34-777-042	9EY 122 979-001	9MX 563 716-022	001 810 39 16	077 3941 386	9EY 111 231-001	81.63730.6314	9SB 501 325-002
1-34-777-057	9MX						



MAN	Hella	Mekra	Hella	Mercedes-Benz	Hella	Mercedes-Benz	Hella
81.63731.0232	9BP 561 006-012	51.2491.121	8SB 003 609-011	357 810 70 93	8SB 501 190-082	901 810 55 16	8SB 507 042-001
81.63731.0248	9XD 562 800-052	51.2493.111	8SB 004 288-001	357 811 12 11	9BP 501 238-022	901 810 57 16	8SB 507 042-011
81.63731.0257	9HD 562 802-012	51.2493.131	8SB 004 288-103	381 810 25 16	8SB 003 978-001	901 810 58 16	8SB 507 042-021
81.63731.6134	8HG 561 108-002	51.2510.127	8SB 560 991-012	381 810 25 16	9EY 125 314-001	901 810 60 16	8SB 507 042-031
81.63731.6281	9BP 501 238-002	51.2510.147	8SB 560 991-041	381 810 26 16	8SB 003 978-041	901 810 61 16	8SB 507 042-041
81.63731.6304	9BP 561 138-052	51.2530.140	8SB 003 978-041	381 810 37 16	8SB 501 081-031	901 810 63 16	8SB 507 042-051
81.63731.6407	8HG 503 009-012	51.2540.120	8SB 003 614-001	381 810 37 16	8SB 501 081-041	901 810 64 16	8SB 507 043-001
81.63731.6408	8HG 503 009-042	51.2540.130	8SB 003 614-081	381 810 71 16	8SB 003 978-001	901 810 66 16	8SB 507 043-011
81.63731.6414	8HG 503 019-012	51.2540.140	8SB 003 614-011	381 810 71 16	9EY 125 314-001	901 810 67 16	8SB 507 043-021
81.63731.6416	8HG 503 019-022	51.2580.120	8SB 501 081-031	381 810 73 16	8SB 003 978-041	901 810 69 16	8SB 507 043-031
81.6373.20058	9HB 863 833-001	51.2580.140	8SB 501 081-041	406 810 04 16	8SB 002 994-001	901 810 70 16	8SB 507 043-041
81.63733.0012	9EY 117 125-001	51.2587.148	8SB 501 081-082	406 810 52 16	8SB 002 994-001	901 810 72 16	8SB 507 043-051
81.63733.0015	9EY 117 124-001	51.2890.117	8SB 002 991-182	460 810 01 16	8SB 003 609-011		
81.63733.0019	9EY 111 231-001	51.3300.147	8SB 501 190-082	460 810 03 16	8SB 003 609-011		
81.63733.0021	9EY 111 231-001	51.3410.127	8SB 501 156-021	460 810 03 16	8SB 003 609-061		
81.63733.0025	9EY 120 010-001	51.3410.147	8SB 501 156-031	601 810 01 16	8SB 003 609-011		
81.63733.0027	9EY 561 042-002	51.3490.110	8SB 507 042-001	601 810 01 16	8SB 003 609-061		
81.63733.0030	9EY 120 010-001	51.3490.112	8SB 507 042-011	601 810 02 16	8SB 003 609-061		
81.63733.0032	9EY 561 042-002	51.3490.120	8SB 507 043-001	603 810 09 16	8SB 004 288-103		
81.63733.0038	9EY 125 314-001	51.3490.122	8SB 507 043-011	603 811 01 30	8SB 003 609-061		
81.63733.0042	9EY 561 814-001	51.3680.147	8SB 501 274-001	603 811 01 30	8SB 004 288-001		
81.63733.0061	9EY 561 814-001	51.3680.167	8SB 501 273-001	611 810 00 16	8SB 004 288-001		
81.63733.0064	9EY 120 010-001	51.3735.124	8SB 501 325-012	611 810 01 16	8SB 004 288-001		
81.63733.0067	9MX 563 468-002	51.3735.126	8SB 501 325-002	627 811 00 60	9HD 564 310-002		
81.63733.0082	9MX 863 837-001	51.3736.124	8SB 501 325-012	627 811 01 10	9GD 564 312-002		
81.6373.30083	9MX 863 838-001	51.3736.126	8SB 501 325-002	641 810 42 16	8SB 501 274-001		
81.63733.0085	9MX 863 848-001	51.3921.222 H	8SB 354 504-011	641 810 44 16	8SB 501 273-001		
81.63733.0087	9MX 863 847-001	51.3922.222H	8SB 354 504-021	641 810 44 16	8SB 501 274-001		
81.63733.6001	9MX 561 044-002	51.3922.222H	8SB 354 505-021	663 811 00 30	8SB 003 609-011		
81.63733.6003	9MX 560 096-002	51.4490.218	8SB 502 991-001	663 811 00 30	9EY 117 126-001		
81.63733.6006	9EY 561 814-001	53.1960.161	8SB 507 047-001	670 810 60 93	8SB 501 358-002		
81.63733.6006	9MX 560 096-002	53.1960.162	8SB 507 047-011	670 810 61 93	8SB 501 358-012		
81.63733.6006	9MX 561 891-001	53.1961.161	8SB 507 048-001	670 810 62 93	8SB 501 358-032		
81.63733.6007	9MX 561 890-001	56.2660.127	8SB 501 147-021	670 810 65 93	8SB 501 359-002		
81.63733.6017	9MX 562 846-002	56.2660.147	8SB 501 147-031	670 810 66 93	8SB 501 359-012		
81.63733.6023	9MX 562 841-002	56.9931.222H	8SB 354 505-011	670 810 67 93	8SB 501 359-022		
81.63733.6024	9MX 563 468-002	58.3701.130H	8HG 863 841-001	671 810 14 16	8SB 501 346-022		
81.63733.6033	9MX 863 837-001	58.3701.140H	8HG 863 842-001	673 810 08 16	8SB 003 978-001		
81.6373.36034	9MX 863 838-001	59.2652.110	8SB 501 137-031	006 820 02 42	9MN 562 843-002		
81.63733.6037	9MX 863 848-001	59.3491.110	8SB 507 042-021	006 820 08 42	9MN 562 844-032		
81.63733.6042	9MX 863 847-001	59.3491.112	8SB 507 042-031	006 820 23 42	9MN 562 844-032		
81.68733-0040	9MX 561 449-001	59.3491.120	8SB 507 043-021	006 820 23 42	9SV 562 829-002		
81.96420-0495	9GH 562 803-002	59.3491.122	8SB 507 043-031	006 820 81 10	9SV 562 829-002		
83.63730-8520	8SB 501 311-842	59.3492.110	8SB 507 042-041	000 810 00 16	6GM 500 212-012		
83.63730-8521	8SB 501 247-822	59.3492.112	8SB 507 042-051	000 810 01 48	8XD 564 323-002		
84.63733.8002	9MX 127 585-002	59.3492.120	8SB 507 043-041	000 810 01 58	8HS 563 390-002		
88.63700.8008	8SB 501 246-812	59.3492.122	8SB 507 043-051	000 810 02 79	8SB 507 046-001		
88.63700.8009	8SB 501 247-812	59.3495.110	8SB 507 042-001	000 810 03 79	8SB 507 046-011		
88.63700.8037	8SB 501 602-812	59.3495.112	8SB 507 042-011	000 810 04 16	9BP 561 138-013		
88.63700.8038	8SB 501 511-802	59.3495.120	8SB 507 043-001	000 810 04 16	8SB 003 614-001		
88.63700.8038	8SB 002 405-001	59.3495.122	8SB 507 043-011	000 810 06 11	9BP 561 006-012		
88.63700.8030	8SB 003 978-041	59.3496.110	8SB 507 042-021	000 810 06 16	8SB 003 614-081		
88.63700.8053	8SB 501 325-012	59.3496.112	8SB 507 042-031	000 810 07 12	9SV 562 840-003		
88.63700.8054	8SB 501 325-002	59.3496.120	8SB 507 043-021	000 810 11 11	9MX 562 846-002		
88.63731.6090	9BP 501 238-022	59.3496.122	8SB 507 043-001	000 810 15 16	8SB 002 995-031		
88.63731.6100	8HG 503 009-022	59.3497.110	8SB 507 042-041	000 810 20 16	8SB 003 614-081		
88.63731.6100	8HG 503 009-082	59.3497.112	8SB 507 042-051	000 810 20 33	9MX 564 234-001		
88.63731-6101	8HG 503 009-022	59.3497.120	8SB 507 043-041	000 810 23 16	8SB 003 978-041		
88.63731-6102	8HG 503 009-052	59.3497.122	8SB 507 043-051	000 810 45 16	8SB 501 147-003		
88.63731-6127	9HD 563 475-041	59.3702.431 H	8SB 354 506-801	000 810 63 16	8SB 501 081-082		
		59.3712.441 H	8SB 354 506-811	000 810 94 16	8SB 507 044-011		
		59.3941.222H	8SB 354 509-001	000 810 95 16	8SB 507 044-001		
		61.3700.231H	8SB 863 843-001	000 810 96 16	8SB 507 045-001		
		61.3710.241H	8SB 863 844-001	000 811 00 44	9GD 564 362-002		
		61.3730.326H	8SB 354 507-001	000 811 00 93	9GH 562 803-002		
		61.3752.147	8SB 507 046-001	000 811 02 06	9HB 564 363-002		
		61.3752.167	8SB 507 046-011	000 811 02 60	9HB 564 363-002		
		61.3772.147	8SB 507 045-001	000 811 02 86	9SV 562 829-002		
		61.3782.147	8SB 507 044-001	000 811 03 25	9XD 564 384-002		
		61.3782.167	8SB 507 044-011	000 811 03 60	9HB 564 364-002		
		61.3860.214H	8SB 354 508-001	000 811 04 25	9XD 564 376-002		
		08.3700.326H	9MN 863 849-001	000 811 04 60	9HB 564 365-002		
		09.2000.301	8KA 500 218-002	000 811 05 61	9HB 564 381-002		
		09.2070.101	8KA 503 806-001	000 811 05 60	9HD 564 383-002		
		09.2070.101	8KA 500 218-002	000 811 06 33	9EY 117 129-001		
		09.2070.101	8KA 560 217-002	000 811 06 60	9BG 562 812-002		
				000 811 06 61	9HD 564 316-002		
				000 811 07 60	9BG 562 814-002		
				000 811 08 60	9HB 562 837-022		
				000 811 09 60	9HB 564 360-002		
				000 811 10 33	9EY 111 231-001		
				000 811 10 33	9EY 117 127-001		
				000 811 10 61	9HD 562 802-012		
				000 811 15 60	9BG 562 813-002		
				000 811 19 33	9EY 122 979-001		
				000 811 20 33	9EY 561 042-002		
				000 811 21 33	9EY 125 314-001		
				000 811 23 33	9EY 120 010-001		
				000 811 33 33	9EY 125 314-001		
				000 811 34 33	9EY 561 445-001		
				000 811 35 33	9EY 122 979-001		
				000 811 38 33	9MX 561 449-001		
				000 811 46 30	8SB 002 995-011		
				000 811 66 33	9MX 560 096-002		
				000 811 67 33	9EY 117 124-001		
				000 811 74 33	9EY 125 314-001		
				000 811 80 33	9EY 561 814-001		
				000 811 84 33	9EY 563 168-001		
				000 821 01 29	9MX 563 167-001		
				000 840 84 16	8SB 501 081-082		
				901 810 01 16	8SB 507 042-001		
				901 810 02 16	8SB 507 043-001		
				901 810 09 16	8SB 507 042-011		
				901 810 10 16	8SB 507 043-011		
				901 810 25 16	8SB 507 042-021		
				90			



Opel	Hella	Volvo	Hella
V04108600	8SB 002 405-001	1 697 926	9EY 125 314-001
Renault	Hella	1 697 926	9MX 127 585-002
60 05 025 880	9EY 561 445-001	1 699 016	9MX 564 239-001
60 05 028 116	8SB 501 081-031	1 699 017	9MX 564 239-011
77 00 061 701	8HG 501 430-802	1 699 700	9MX 561 890-001
77 00 061 702	8HG 501 430-812	2 612 573	9EY 120 010-001
77 00 066 842	8SB 004 288-092	2 628 194	9MX 560 096-002
77 00 075 781	6GM 500 212-012	280 536 3	8SB 004 288-001
Renault V.I.	Hella	280 837 9	8SB 004 288-103
60 05 025 880	9EY 561 445-001	290 715 6	8SB 004 288-092
60 05 028 116	8SB 501 081-031	3 090 736	9MX 564 214-012
77 00 061 701	8HG 501 430-802	3 090 737	9MX 564 215-012
77 00 061 702	8HG 501 430-812	3 091 756	9MX 564 215-012
77 00 066 842	8SB 004 288-092	3 570 244	8SB 002 405-011
77 00 075 781	6GM 500 212-012	5 252 000 1	8SB 501 156-031
Same	Hella	52 53 0004	8KA 500 218-002
16000669	8SB 501 190-082	5 253 000 5	8SB 501 156-021
04358888	8SB 002 991-081	52 53 0005	8SB 501 156-021
04398697	9EY 117 126-014	52 530 006	8SB 501 602-812
04412581	8SB 501 263-003	52 530 007	8SB 501 246-822
0443 9549	9XD 564 924-002	52 53 0008	9MX 562 846-002
0.900.0025.2	8HS 562 691-002	5 253 000 9	9MX 562 841-002
SAW	Hella	52 530 009	9MX 562 841-002
61.096-001	8SB 003 609-061	5 256 000 3	9BP 561 138-013
61.097-001	8SB 002 995-001	52 560 003	9BP 561 138-013
61.097-021	8SB 002 995-011	589990057400	6GM 500 212-002
61.100-001	8SB 003 290-001	589990057890	8SB 501 246-902
61.102-001	8SB 003 614-001	58999005789006	9GH 562 803-002
61.103-001	8SB 003 978-001	5899900578904	9XD 563 637-012
94.068-001	9EY 117 125-001	589990057910	9BP 501 238-022
94.069-001	9EY 117 126-001	6 793 879	8SB 003 978-001
94.071-241	9MX 561 044-002	6 793 880	8SB 003 978-041
94.100-001	9EY 120 010-001	7 030 510 8	8SB 501 311-842
94.102-001	9EY 122 979-001	7 031 137 8	8SB 501 247-812
94.103-001	9EY 125 314-001	7 031 573 1	8SB 501 246-892
94.103-241	9MX 127 585-002	7 032 360 1	9BP 501 238-022
Scania	Hella	7 032 827 4	8SB 501 246-822
1 434 030	9MX 562 841-002	7 035 305 6	9BG 562 812-002
1 468 418	8SB 501 247-803	7 035 305 7	9BG 562 814-002
1 505 202	9HB 863 833-001	7 035 306 0	9HD 562 802-012
482 034	9BP 501 237-002	7 035 306 1	9GH 562 803-002
487 668	8SB 560 991-012	7 035 308 5	9BG 562 813-002
Schmitz	Hella	7 035 308 8	9MX 562 846-002
Cargobull	Hella	8706001900012	9MX 562 841-002
1-FZELEK0146	8SB 003 609-061		
980924	8SB 560 991-012		
980949	8SB 501 147-021		
Sisu	Hella		
112-440-0171	8SB 003 290-011		
112-441-1310	9MX 127 585-002		
SMAT Nord	Hella		
5.594.025	8SB 002 993-001		
Steinbock	Hella		
000 23044	8SB 002 997-001		
745 204010032	8SB 002 405-001		
Steyr	Hella		
161.00.77.0099	8SB 002 995-041		
3.477.70.42	9EY 122 979-001		
5.899.90.058.06.0	8SB 501 246-892		
5.899.91.057.89.0	8SB 501 246-902		
5.899.91.057.90.0	8SB 501 247-803		
721.1.83.106.0	8SB 003 609-061		
Still	Hella		
1001309	9EY 111 231-001		
1001313	8SB 002 992-001		
Ulo	Hella		
6016-03	8SB 501 274-001		
6102-02	8SB 501 273-001		
Volkswagen	Hella		
281 857 547	8SB 002 995-011		
281 857 547 B	8SB 501 045-002		
2D1 857 501A 01C	8SB 507 042-001		
2D1 857 501C 01C	8SB 507 042-011		
2D1 857 502A 01C	8SB 507 043-001		
2D1 857 502C 01C	8SB 507 043-011		
2D3 857 501D 01C	8SB 507 042-021		
2D3 857 501E 01C	8SB 507 042-031		
2D3 857 501F 01C	8SB 507 042-041		
2D3 857 501G 01C	8SB 507 042-051		
2D3 857 502D 01C	8SB 507 043-021		
2D3 857 502E 01C	8SB 507 043-031		
2D3 857 502F 01C	8SB 507 043-041		
2D3 857 502G 01C	8SB 507 043-051		
2TA 857 547	8SB 501 147-021		
600 857 521	9MX 561 044-002		
600 857 539	9EY 561 042-002		
690 857 539	9EY 561 814-001		
701 857 507 C	8SB 507 047-001		
701 857 507 C	8SB 507 047-011		
701 857 508 C	8SB 507 048-001		
Volvo	Hella		
1 112 115 2	8SB 501 081-031		
1 112 115 3	8SB 501 081-041		
1 170 894 5	9EY 561 445-001		
1 581 550	8SB 501 156-021		
1 581 599	9EY 120 010-001		
1 581 602	9MX 560 096-002		
1 581 602	9MX 561 891-001		
1 594 412	8SB 501 156-031		
1 594 415	9MX 560 096-002		
1 599 462	8SB 501 081-031		
1 607 981	8SB 501 147-031		

Das breite Programm für:

- *Hauptspiegel*
- *Weitwinkelspiegel*
- *Rampenspiegel*
- *Komplette Spiegelsysteme*

Das Spiegelprogramm deckt eine Vielzahl von Fahrzeugen ab. Angefangen bei Transportern, Nkw sowie Land- und Baumaschinen bis hin zu Bussen.

Coachline® – das brandneue modulare Spiegelsystem für Busse mit innovativem Design zur optischen Differenzierung.

Standardspiegel-Grundprogramm mit verschiedenen Garnituren für alle Busstypen.

A wide range covering:

- *Main mirrors*
- *Wide-angle mirrors*
- *Ramp mirrors*
- *Complete mirror systems*

The mirror range covers numerous vehicles from vans, commercial vehicles, construction and agricultural machinery, to buses.

Coachline® – the brand new modular mirror system for buses. – An innovative design for a distinctive look.

A range of standard mirrors with different sets for all bus models.

Une gamme étendue pour :

- *Rétroviseurs principaux*
- *Rétroviseurs angle large*
- *Rétroviseurs d'angle mort*
- *Systèmes de rétroviseurs complets*

La gamme des rétroviseurs couvre un grand nombre de véhicules. Pour VUL, VU, cars et bus, machines agricoles et engins TP.

Coachline® – le tout nouveau système de rétroviseur modulaire pour les bus, avec un design innovant marquant sa différence.

Gamme de base de rétroviseurs standard avec différentes garnitures pour tous les types de bus.

Amplio programa para:

- *Retrovisores principales*
- *Retrovisores panorámicos*
- *Retrovisor para ángulo muerto*
- *Sistemas completos de retrovisores*

El programa de retrovisores cubre un gran número de vehículos: furgonetas, vehículos industriales, maquinaria agrícola, obras públicas y autobuses.

“Coachline®” es el moderno sistema modular de retrovisores para autocares con un diseño innovador.

Programa básico de retrovisores estándar para todo tipo de autobuses.

Vasto programma di:

- *Specchietti principali*
- *Specchietti a grandangolo*
- *Specchi di rampa*
- *Sistemi di specchietti completi*

Il programma di specchietti copre un ampio numero di veicoli: dai furgoni, ai veicoli commerciali, alle macchine agricole ed edili fino agli autobus.

Coachline® – Il nuovissimo sistema di specchietti modulare per gli autobus, con design innovativo per distinguersi a livello ottico.

Programma base di specchietti standard con rifiniture diverse per tutti i tipi di autobus.

Het brede programma voor:

- *Standaard spiegels*
- *Groothoekspiegels*
- *Dodehoekspiegels*
- *Complete spiegelsystemen*

Het spiegelprogramma bevat spiegels voor vrijwel alle voertuigen. Van transporters, bedrijfswagens en (land-) bouwmachines tot bussen.

Coachline® – het gloednieuwe modulaire spiegelsysteem met innovatief design voor optische accenten.

Basisprogramma met standaardspiegels met diverse accessoires voor alle bustypen.

*Ideas today for
the cars of tomorrow*

